

Processing Techniques and Productions of Ductile Iron: A Review

J.O. Olawale, S.A. Ibitoye, K.M. Oluwasegun

Abstract—Ductile cast irons are materials having strength, impact toughness and ductility comparable to those of many grades of steel while exceeding by far those of standard gray irons. In addition, they have the same advantages of design flexibility and low cost casting procedures of cast irons. Their corrosion resistance is equal or superior to that of gray cast iron and cast steel in many corrosive environments. Its wear resistance is comparable to some of the best grades of steel and superior to gray iron under heavy load or in impact situations. They are considerably less expensive than cast steels to produce and only moderately more expensive than gray cast irons because the procedures are similar. The combination of good mechanical properties and casting abilities of ductile cast iron makes it economical choice for many applications. Practical examples are valves, pumps, cylinder liners, crankshafts, metal working rolls, dies, gears, process equipment and structural applications. This paper reviews the process techniques and applications of ductile cast irons.

Index Terms— Ductile iron, Graphite, Spheroidizing, Inoculation, Flakes, Nodules, Nodularizer

1 INTRODUCTION

Ductile iron is a ferrous alloy consisting primarily of iron with carbon and silicon. Other elements are also present and controlled to produce the various grades and to influence other mechanical properties, machinability, and castability. Carbon is added to iron in amounts that exceed the solubility limit, and during solidification, graphite precipitates into tiny spheres. Silicon and other alloys are used to control the morphology of the precipitated graphite and to control the amount of carbon that remains as a solid solution in the iron. The carbon content is typically between 3 – 4% and the silicon content between 2 – 3% which gives a eutectic solidification temperature of about 1165 °C. The amount of carbon that remains in solid solution depends on the rate of solidification and cooling, on the inoculation practice, and on other elements that are added to either promote graphitization or to promote the formation of pearlite. It is possible to produce the different grades of ductile iron by controlling the process variables to precipitate the desired amount of graphite particles and obtain the desired amount of combined carbon remaining in the matrix [1].

Ductile iron was invented in the mid 1940's somewhat by accident when a metallurgist was trying to find a replacement for chrome in wear-resistant gray iron castings. Magnesium was used in one of the experiments, and it was discovered that what were normally flake graphite shapes were now spheroidal.

Castings made with spheroidal rather than flake graphite had high strength and ductility, good fatigue life, and impact properties. Other properties such as vibration damping, machinability, and wear resistance have made ductile iron a suitable replacement for steel in gears and a number of other applications.

The main structural difference between nodular cast iron and gray cast iron is in the graphite form. Ordinary gray cast iron is characterized by a distribution of random lamellae of graphite in the metal matrix, while in nodular cast iron the graphite has the form of small spheroids. With respect to lamellae, the spheroids create fewer and less severe discontinuities in the metal matrix thus producing a stronger, more ductile cast material [2]. This new form of cast iron immediately found uses where malleable iron, forgings, cast steel or steel fabrications would have been used. From this point, ductile cast iron grew into a world class material offering cast solutions at a competitive price compared to traditional alternatives.

The advantages of ductile iron which have led to its success are numerous, but they can be summarized easily - versatility and higher performance at lower cost. Other members of the ferrous casting family may have individual properties which might make them the material of choice in some applications, but none have the versatility of ductile iron, which often provides the designer with the best combination of overall properties [3-6]. This versatility is especially evident in the area of mechanical properties where ductile iron offers the designer the option of choosing high ductility, with grades guaranteeing more than 18% elongation, or high strength, with tensile strengths exceeding 825 MPa [7], [8].

In addition to the cost advantages offered by all castings, ductile iron, when compared to steel and malleable iron castings, also offers further cost savings. Like most commercial cast metals, steel and malleable iron decrease in volume during

-
- Dr. Olawale J.O. is currently a Lecturer I in the Department of Materials Science and Engineering, Obafemi Awolowo University, Nigeria, PH-+2348034289578. E-mail: joolawale@yahoo.com
 - Prof. Ibitoye S.A is currently a Professor in the Department of Materials Science and Engineering, Obafemi Awolowo University, Nigeria, PH-+2347030305596. E-mail: demolaibitoye@yahoo.com
 - Dr. Oluwasegun K.M. is currently a Lecturer I in the Department of Materials Science and Engineering, Obafemi Awolowo University, Nigeria, PH-+2347035552287. E-mail: excetom@yahoo.com

solidification, and as a result, require attached reservoirs (feeders or risers) of liquid metal to offset the shrinkage and prevent the formation of internal or external shrinkage defects. The formation of graphite during solidification causes an internal expansion of ductile iron as it solidifies and as a result, it may be cast free of significant shrinkage defects either with feeders that are much smaller than those used for malleable iron and steel or, in the case of large castings produced in rigid moulds, without the use of feeders [9]. The reduction or elimination of feeders can only be obtained in correctly designed castings. This reduced requirement for feed metal increases the productivity of ductile iron and reduces its material and energy requirements, resulting in substantial cost savings. The use of the most common grades of ductile iron "as-cast" eliminates heat treatment costs, offering a further advantage.

Ductile iron is not a single material, but a family of materials offering a wide range of properties obtained through microstructural control. The common feature that all ductile irons share is the roughly spherical shape of the graphite nodules. With a high percentage of graphite nodules present in the structure, mechanical properties are determined by the ductile iron matrix. A number of variables including chemical composition, cooling rate, type, amount and method of post inoculation, amount of residual magnesium and pouring temperature can control the matrix structure of ductile iron [10]. The importance of matrix in controlling mechanical properties is emphasized by the use of matrix names to designate the ductile iron as ferritic, pearlitic and ferritic-pearlitic ductile iron with graphite spheroids in a matrix of ferrite, pearlite and ferrite-pearlite respectively [11].

Over the years a number of process parameters have been developed to introduce magnesium into gray cast iron to change its morphology from graphite flakes to nodules. The most common process techniques in use today are: plunging, autoclave/pressure ladle, treatment converter, cored wire, open ladle, sandwich, tundish, porous plug, in-mould, and flow-through. This review reports the extensive production process of these techniques and the applications of ductile cast iron.

2 PRODUCTION OF DUCTILE IRON

Ductile iron is made by the treatment of molten iron with nodulizing (spheroidizing) material. During this treatment, graphite changes from flakes to nodules or spheres. The treatment process is a key operation in the production of ductile iron that ensures a predetermined microstructure, and mechanical and engineering properties of castings.

Production of ductile iron is influenced by a large number of metallurgical, technological, heat transfer and designing parameters. The first step of the production of ductile iron castings is the careful selection of the charge materials. Manganese and chromium have the most influence on all mechanical properties [12]. For this reason, their concentration in metal is

of particular importance. These elements arise in the charge from steel scrap, pig iron and foundry returns. It is a recommended practice to select steel scrap so that the average Cr content remains below 0.1%. Ideally, the same advice would be given for Mn but, unfortunately, all steel scraps contain Mn, the majority being at 0.5% level. The amount of steel scrap in the charge must be such that the castings produced are free of carbides as much as possible [13]. It is particularly important for the production of ferritic ductile iron [14].

Charge materials result in the average size of graphite spheroids. For instance, if the amount of steel scrap in the charge is higher than 50%, then an average spheroids diameter is 33 μm and if it is 30%, then the average diameter is 57 μm [15]. The amount of steel scrap affects metallic matrix structure too. It increases the pearlite formation [16].

The graphite structure is affected by the carbon content as well. If initial metal does not contain enough carbon then graphite particles will be of compact shape [17]. The metallic matrix structure is affected not only by carbon equivalent but by C/Si ratio too. As this ratio increases in ductile iron, the proportion of ferrite decreases and the proportion of pearlite increase [18].

It must also be pointed out that charge materials contain elements that decrease the quantity of spheroids and have effect on the matrix structure. For instance, to achieve a ferritic casting in as-cast condition, chemical composition of charge materials should not contain more than 0.01% Sn, 0.02% As, 0.1% $\Sigma(\text{V} + \text{Mo})$, 0.04% Cr, 0.02% S and 0.05% P [19].

The formation of graphite spheroids is obtained through a special treatment during which spheroidising elements are added to the melt. Magnesium and various Mg alloys are the most commonly used for spheroidisation of ductile iron [20]. There are three ways to inoculate with metals used either individually or in combination: in the ladle, in the stream while pouring and in the mould.

2.1 Graphite Nodulizer and Inoculants of Ductile Iron

Ductile iron solidifies and crystallises into Hexagonal Close-Packed (HCP) structure. The top and bottom plane of the hexagon are called basal plane and the six sides are the prismatic planes. According to Franklin and Stark [21], flake graphite occurs predominantly on the prism plane of the hexagonal graphite lattice and takes place as a coupled eutectic austenite in contact with melt. Nodular graphite growth occurs on the basal plane by a defect controlled spiral growth mechanism as a divorced eutectic, the graphite nodules being surrounded by liquid iron during the initial part of the growth process. However, the graphite nodules being formed on the basal plane at the onset of graphite formation in gray irons later grow into flakes as a result of the activity of the surface elements. The surface active elements such as sulphur (S) and oxygen (O) hinder the process of nodularization on prism plane by adsorbing on certain crystallographic planes [21].

Several investigators [22], [23], [24], [25] in their respective works reported the dependence of the role of nodularising agents on sulphur and oxygen concentrations in iron melt. These nodularizing agents display higher affinity for the two elements and hence, combine with them instead of absorbing them on the prism planes. In this way the basal planes of the graphite lattice acquire a more favorably lower surface energy in contact with liquid iron, a condition that enhances the growth mechanism of nodular graphite [26], [27], [28].

Magnesium (Mg) treatment is the most common spheroidizing element used in the ductile iron production since its discovery in 1943 at International Nickel Company Research Laboratory [29]. It is usually added in multicomponent alloy form with silicon (Si), calcium (Ca), and rare earths. Such alloys are balanced to reduce the reaction violence, to promote graphite spheroidizing, to neutralize the effect of impurities on graphite morphology and to control the matrix structure. The most common materials for nodularizing ductile iron are ferrosilicon alloys containing about 45% Si, 3 – 12% Mg and various levels of Ca and Ce [30].

Addition of Mg to the molten iron has other effects on ductile iron besides providing conditions for graphite spheroidization. Magnesium is also known as “carbide former”, whereby the eutectic reaction chosen tends to transforming liquid iron to the metastable product of austenite and iron carbide instead of transforming to more stable and desired austenite and graphite. Therefore, in order to counteract the tendency of magnesium to promote formation of iron carbide-austenite

eutectic there is a need to make another addition to the melt. This is accomplished by adding to the melt an inoculant, by which the nucleation rate of the graphite spheroids is increased to the point that the time the eutectic carbide would have begun forming, there is very little or no liquid left to allow the carbide eutectic reaction. Inoculation is a means of controlling the structure and properties of cast iron by minimizing undercooling and increasing the number of graphite nucleation events during solidification. An inoculant is a material added to the liquid iron just prior to casting that will provide a suitable phase for nucleation of graphite nodules during the subsequent cooling [31].

In effect, the inoculant is added to coerce the system into avoiding the natural tendency resulting from Mg additions [32]. This effect of inoculation is vividly illustrated with the aid of cooling curves included with the stable and metastable phase diagram temperatures as shown in Fig. 1. The top cooling curve represents the inoculated iron exhibiting very little undercooling below the stable eutectic at T_C . In this instance, nuclei generated by the action of the inoculant has minimized the undercooling required to drive the reaction to completion; the latent heat associated with the cells of eutectic austenite and graphite growing in the melt has kept the reaction temperature out of the range of the $\gamma + Fe_3C$ eutectic [32]. The other curve illustrates the situation in which little or no graphite, but primarily $\gamma +$ cementite forms because of a lack of graphite nuclei.

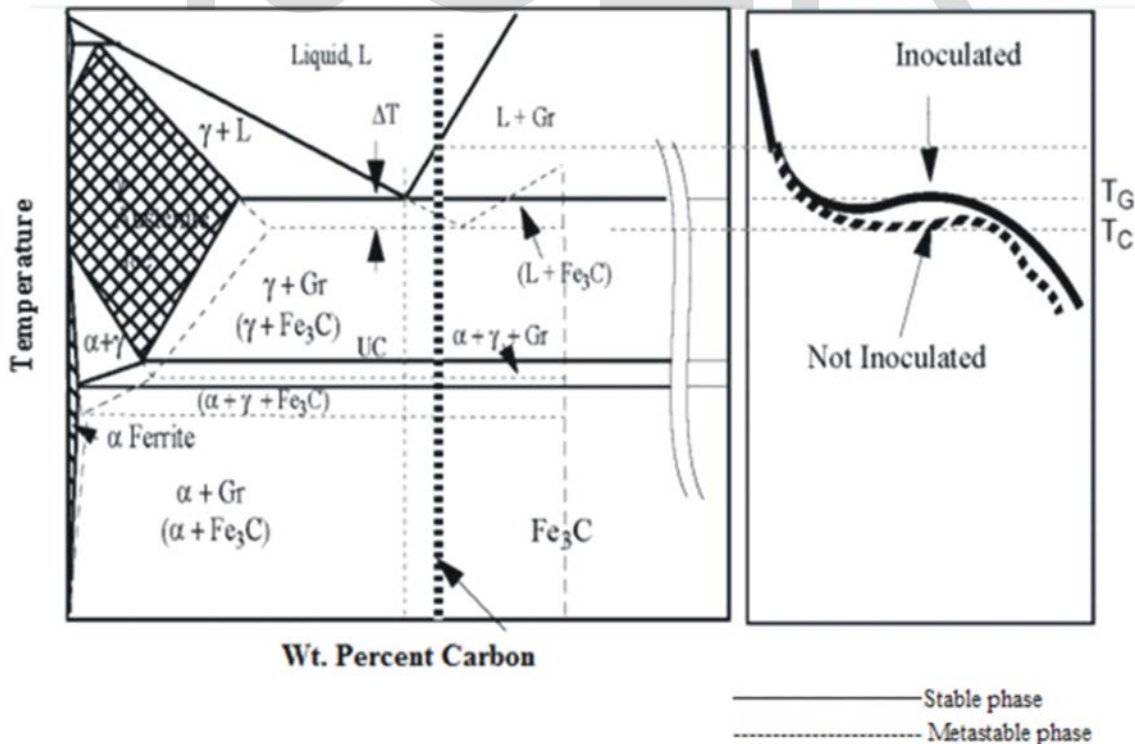

Fig. 1: Schematic illustration of the presence of stable and metastable Fe - C phase diagrams cooling curves for inoculated and not inoculated irons [32].

2.2 Graphite Nodularization with Magnesium

After the initial “accidental” discovery of the magnesium process, two major types of nodularizers have been identified over the years for the production of ductile iron castings. These are the rare-earths metals/alloys: cerium, magnesium and magnesium-calcium based nodularizers (MgFeSi, Mg-Ca-FeSi, Ca-CaC₂-Mg, CaSi-CaF₂, etc.). Also, Umoru *et al.* [33] have successfully used calcium alone as nodulariser. Commercially, the magnesium-based process discovered very early, still enjoys a good patronage in the production of ductile iron.

In modern graphite nodularizing treatments, magnesium still forms the base treatment agent, used in combination with other nodularizing elements, (as masteralloys), or as Fe-Mg-Si alloys [34]. According to Lerner and Pantelev [35], the use of Mg for treating liquid iron has a number of difficulties caused by Mg’s physical properties, such as low melting and boiling temperatures (650 and 1107 °C, respectively), low density (1.738 kg/mm³) relative to molten iron (6.92 kg/mm³), and solubility in liquid iron (about 0.001% wt. at 650 °C).

As a result, the introduction of Mg or Mg-containing alloy into liquid iron is typically accompanied by significant flames and fumes, called “pyroeffect,” which makes the process too violent and unsafe [36]. The latter can cause significant Mg losses due to burning and hence, reduction of residual Mg content in solidified castings. Magnesium losses also occur because of its reaction with other elements contained in liquid iron—primarily with sulphur and secondarily with oxygen. Furthermore, during extended holding before pouring or prolonged pouring, residual Mg content in treated liquid iron gradually decreases, or fades. Fading is a time dependent factor that manifests itself as graphite shape deterioration and nodule count reduction, causing a significant decrease in mechanical properties [36].

Hence, the major obstacle to the usage of magnesium in treatment of melts has been the violent agitation of melt which causes undesirable pyrotechnics, splashing, fading or low recovery of reagent; the low boiling temperature and volatility of magnesium being the cause. Thus the primary problem of technology in this respect has been in moderating the treatment of melt, in finding a method and developing a process of reliable control of magnesium gas formation, in achieving the most complete dissolution of the magnesium vapors, in the high rate of reagent utilization and specific consumption of reagent (Mg is costly!).

According to Lerner and Pantelev [35], the magnesium recovery (Mg_R) depends upon several factors, such as treatment

method, sulphur content in liquid iron to be treated, iron temperature, type and size of nodularizing material, quantity of

iron being treated, and tapping rate. Magnesium recovery (Mg_R) may be calculated using Equation 1.

$$Mg_R = \frac{0.76 \times \Delta S + Mg_{res}}{Mg_{add}} \times 100\% \quad (1)$$

Where:

ΔS = Difference between the sulphur content in the base iron and the treated metal, wt.%;

Mg_{res} = Residual magnesium, wt.%;

Mg_{add} = Magnesium addition, wt.%;

There are several factors which influence process selection and some of these are type of castings to be produced; foundry layout – furnace height/available floor area, quantities and qualities of iron to be produced, treatment weight, environmental consideration, health and safety, treatment cycle time, degree of automation, in built controls, base metal analysis, type of melting and holding furnace [37].

To meet these factors, a number of treatment techniques have been developed over the years [35], [38], [39], [40], [41], [42], [43], [44], [45], [46]. These methods use different approaches to introduce Mg or its alloys into liquid iron: from simple plunging bells, to special ladles or devices, to in-mould treatment techniques. Fig. 2 classifies Mg treatment methods currently been used by foundry industry depending upon the type of Mg additions employed: those utilizing pure Mg and those utilizing Mg master alloy. In turn, Mg master alloys are broken down into two groups, depending upon their relative to that of liquid iron: light master alloys and heavy master alloys. Different treatment methods are employed for each of these groups.

2.2.1 Treatment methods using pure magnesium

Currently, about 40% of the world’s ductile iron production utilizes pure Mg as a treating agent, using special equipment or devices to control the reaction rate and to maximize Mg recovery [35]. Pure Mg is used in the form of ingots, briquettes, pellets, or powder.

Treatment with pure Mg offers a number of common advantages. First, desulphurization can be carried out in the same ladle before or during treatment. Thus, the base iron can be melted in any melting furnace, including a cupola. Second, in contrast to a Mg master alloy, the absence of calcium or aluminum decreases slag build-up during the holding and pouring of treated iron. Finally, if the foundry uses a significant amount of returns, and silicon balance is a problem, the use of pure Mg is an excellent alternative to the FeSiMg master alloy

to avoid the undesirable addition of Si. However, the utilization of pure Mg has some disadvantages. For instance, to improve Mg recovery and to minimize pyroeffect, relative complicated equipment and devices are needed. Due to significant undercooling, and the absence of elements controlling the chill rate and metallic structure, it is necessary to apply sufficient inoculation before or during the pouring of iron [36].

In the case of the use of the traditional pure magnesium, the material is introduced into the molten iron either in the open-

ladle (or in-ladle) method or the pressure-container (converter) method. In both cases, special (mostly proprietary) techniques have been developed and numerous patents have been taken out regarding most of the techniques. Two of these traditional processes; the 'plunging' and the sealed pressure/autoclave ladles have found to be very reliable and still in use.

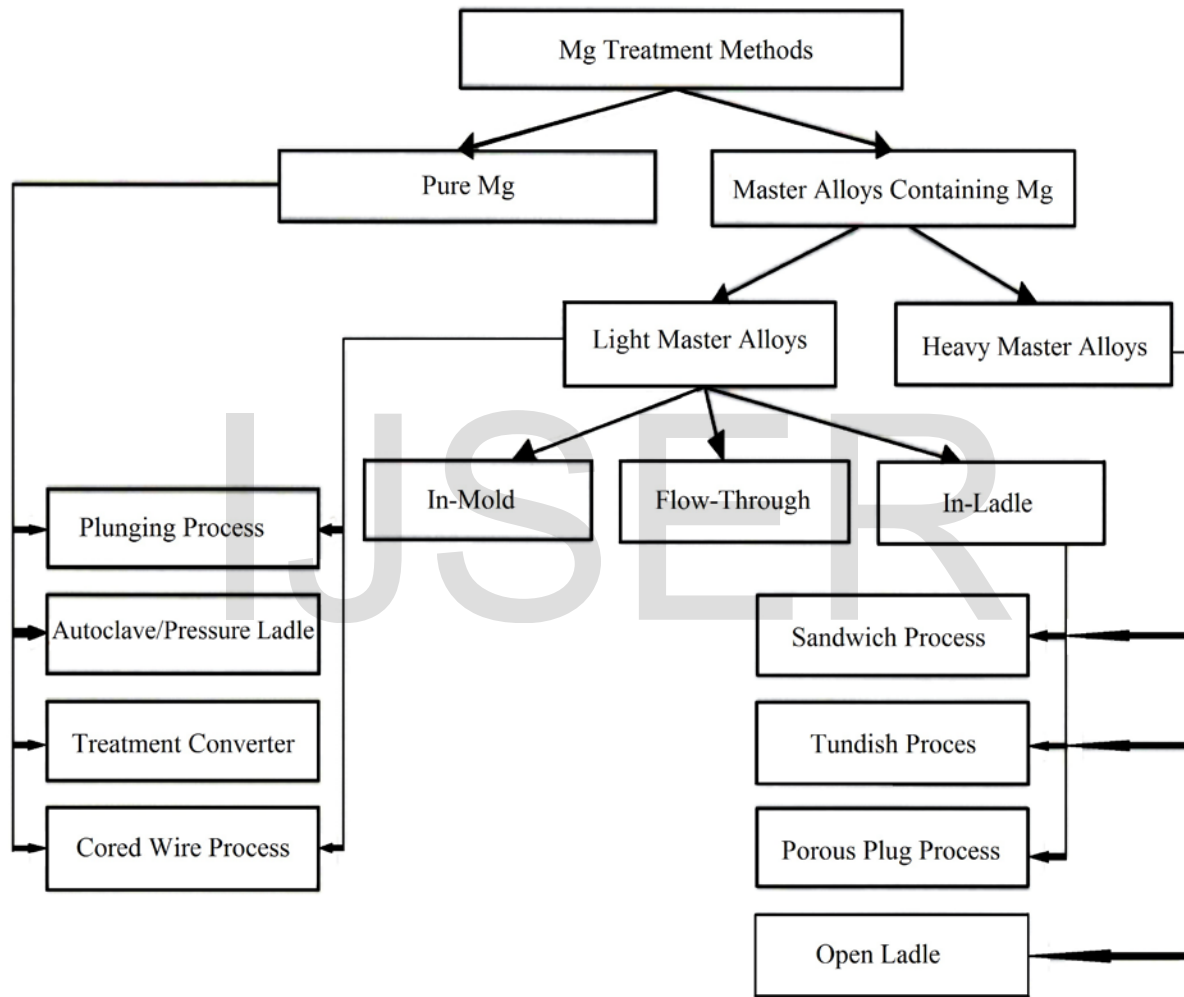

Fig. 2: Classification of Mg-treatment alloys and treatment methods currently used for ductile iron castings [35]

2.2.1.1 Plunging process

The plunging process (Fig. 3) was one of the most widely used for ductile iron production. With this method, the plunging bell, containing pure Mg, Mg-master alloys or Mg-impregnated coke, is plunged into the liquid iron. The plunging bell may be made of refractory coated steel pipe, graphite, or ceramic material. During the treatment, the plunging bell

with nodulizing material is held deeply below the melt surface to provide more uniform distribution of Mg in treated iron and to improve Mg recovery, which does not exceed 30% while using pure Mg and may reach up to 50% when 5 – 6% FeSiMg master alloy is used. In order to ensure better safety and proper environmental conditions, it is recommended to use tall and narrow ladles with the cover.

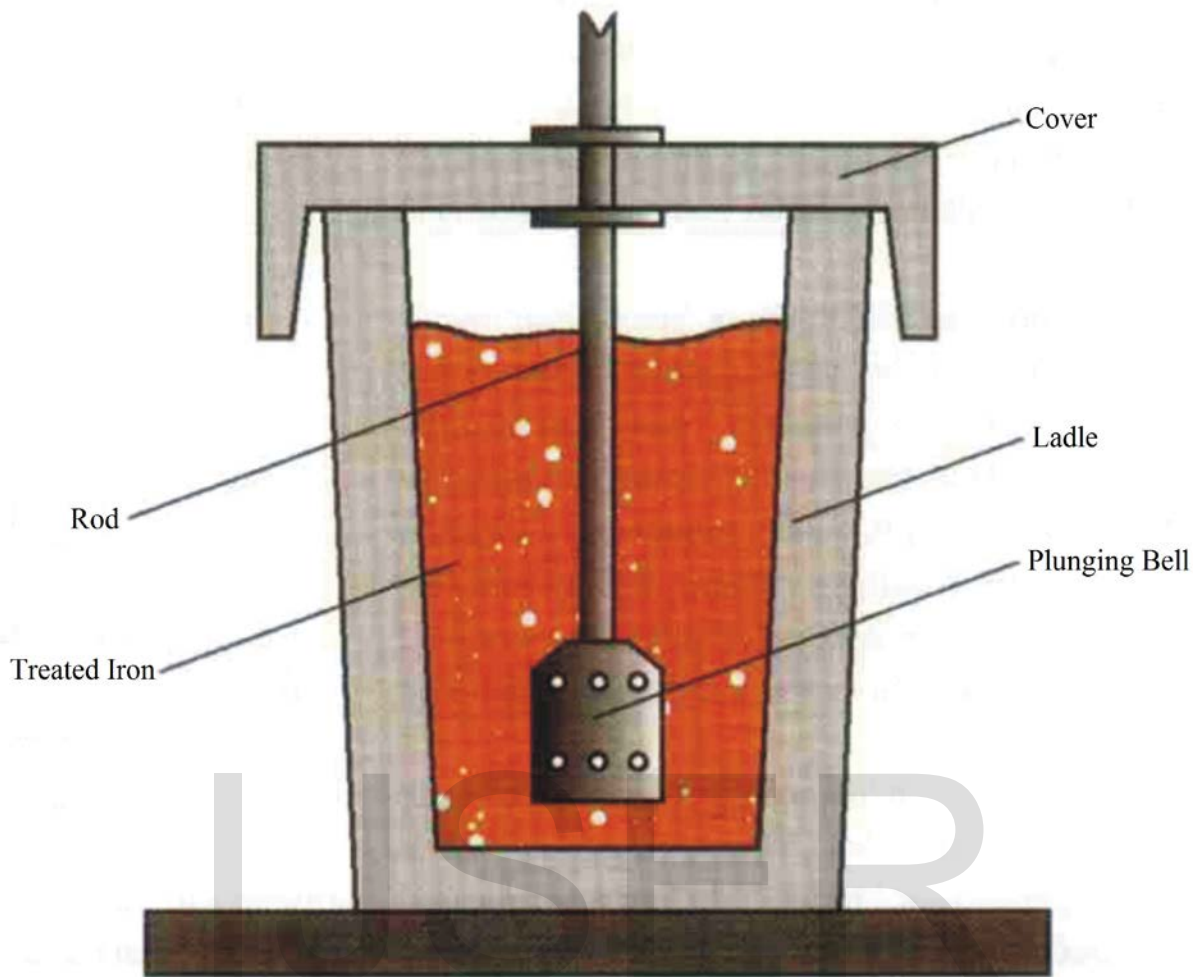

Fig. 3: A schematic diagram of plunging process [35]

There are obvious advantages that still encourage use of the plunging process. First, the method can utilize the full range of nodulizing materials. Second, it has the ability to treat iron with relatively high sulphur content. Finally, it is simple to use. The disadvantages of this method include considerable temperature losses (111 °C), as a result of plunging the large, cold plunging bell with nodulizer, and significant pyroeffect. In addition, due to extreme working conditions of the plunging bell (heat shock, impact, and high temperature erosion), it is often not reusable or requires repair, and after a few treatments needs to be replaced [35].

2.2.1.2 Pressure ladle and autoclave

Pressure and autoclave are two techniques that employ variable air pressure [26]. The difference lies in the pressurising method: in the first case, the ladle itself is a press vessel, where pressure is created by Mg vapors; in the second case, a ladle with liquid iron is placed into pressurized chamber and is subjected to additional air pressure.

In **pressure ladle** (Fig. 4), liquid iron is placed under the movable pressure chamber head. Then, the pneumatically or hy-

draulically operated cover tightly closes the pressure ladle, leaving the central hole for the pressure head. Next, the hydraulic rod with the sealing head plunges the Mg billet into the ladle and finally seals it. The Mg billet is secured in the steel pipe to retard any reaction between the liquid iron and Mg until the ladle is sealed completely. While iron is reacting with Mg, the pressure inside the ladle increases, then returns to its initial level at the end of the reaction. Residual pressure is released when the cover is lifted, and the ladle with treated iron is ready to pour.

In the **autoclave** (Fig. 5), a ladle with liquid iron is placed into water-cooled pressurized vessel. Both autoclaves shown have slightly different designs, but the sequence of operations is almost identical. Because the magnesium is introduced into the liquid iron under excessive air pressure, it melts, does not vaporize, and occurs as a layer of liquid magnesium on top of the liquid iron [45]. A special stirring device mixes the liquid metal layers, thereby, providing successful nodulizing treatment.

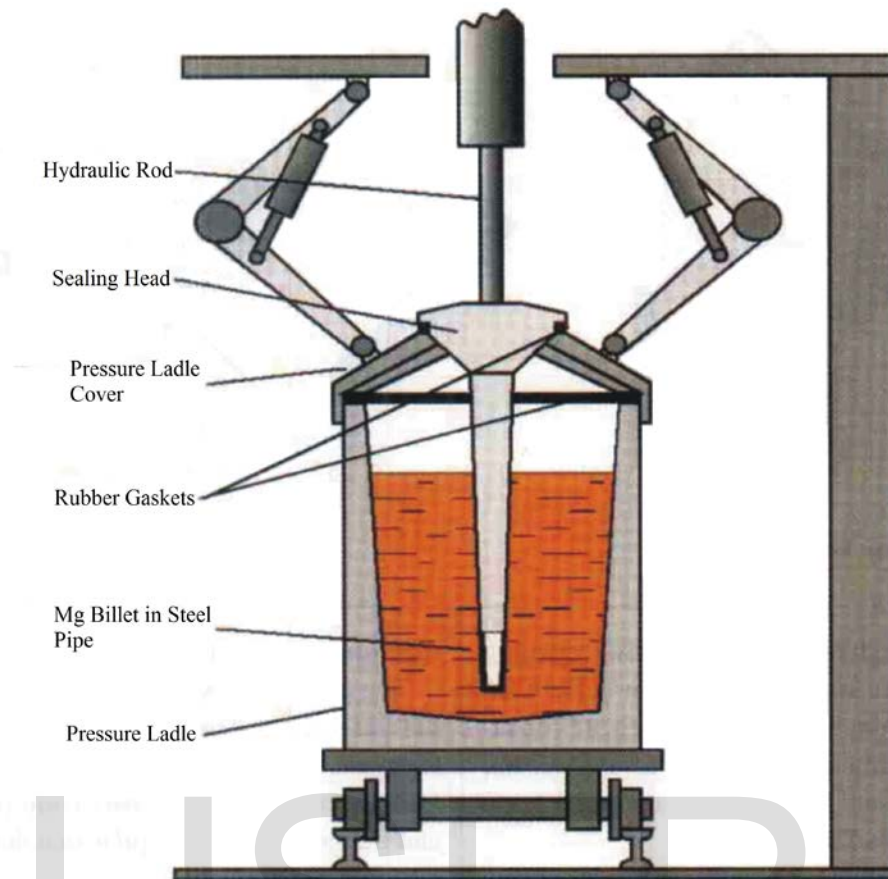

Fig. 4: A schematic diagram of sealed pressure ladle [35]

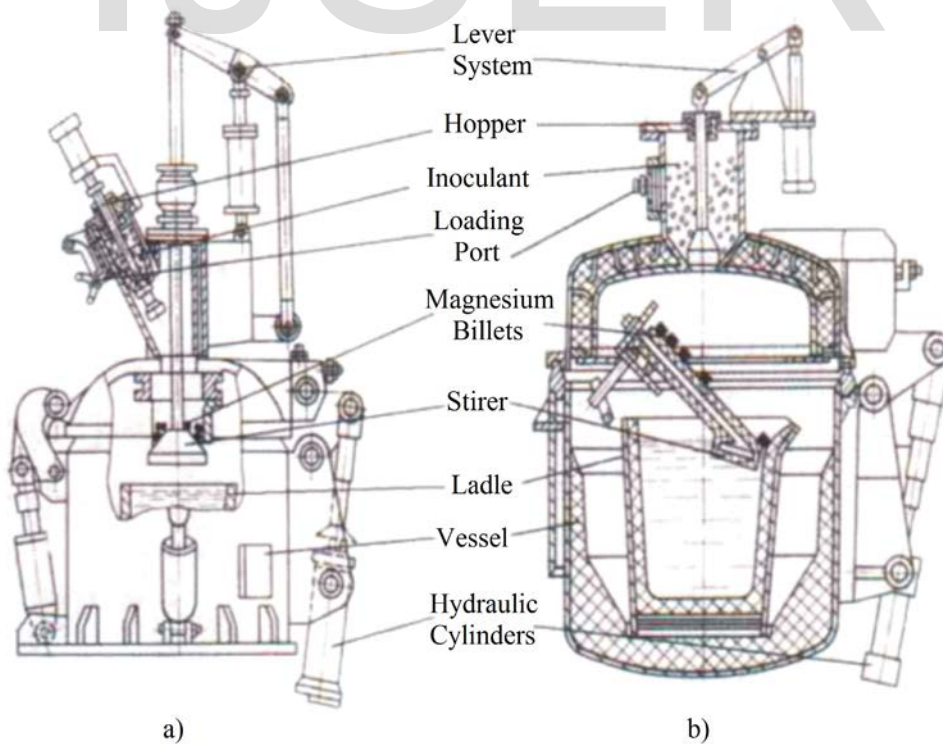

Fig. 5: Schematic diagrams of autoclave for Mg-treatment in ladles [35]

The smaller capacity autoclave (Fig. 5a) has a refractory-lined cover with two separate hoppers for sand inoculants, and stirring mechanism. The treatment cycle includes the following steps: charging the hoppers with required amount of Mg and inoculants, placing the ladle with iron into the autoclave, sealing the autoclave, increasing the pressure, treating iron sequentially, first, with nodulizer and then with inoculants, releasing the high pressure and venting, opening the cover and removing the ladle with treated iron. The cycle time depends on ladle capacity and is 3 – 5 min for 0.5 – 0.7 ton capacity and 8 – 10 min for treating 3 – 5 ton capacity ladle.

The autoclave treatment process has a number of advantages. The recovery may reach up to 70%, depending on base iron temperature and desired residual Mg content. The inoculation is done in the same treatment cycle. The tolerance of sulphur content in the base iron may be up to 0.15%. The process is fully automated and environmentally safe. Autoclaves also allow producing liquid Mg master alloys using the overtreatment/dilution technique.

The major disadvantages of pressure ladle and autoclave processes are significant temperature losses (69 – 100 °C) of treated iron, the relative high cost of equipment, and the necessity for regular maintenance during operation [33].

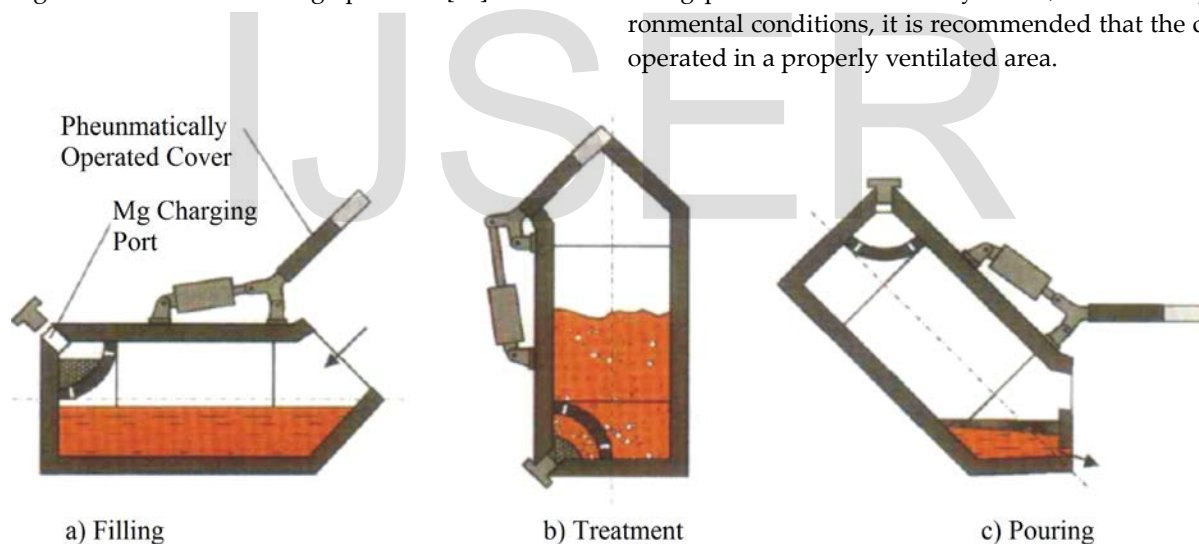

Fig. 6: Schematic diagram of the treatment converter illustrating the treatment sequence [35]

The converter permits the treatment of iron containing a considerable amount of sulphur (up to 0.15%) by providing effective desulphurization that makes possible the use of cupola-melted base iron. Mg recovery in the converter is typically about 50 – 55%. The disadvantages of this method include considerable financial investment, a relatively long treatment cycle, and post-inoculation, typically, in-stream inoculation for automated holding-pouring systems.

2.2.1.4 Cored wire

The cored wire process (Fig. 7) is a treatment method utilizing

2.2.1.3 Treatment converter

A treatment converter (Fig. 6) is a tilting cylindrical vessel lined with a refractory material. The converter is furnished with a perforated reaction chamber at the bottom of the vessel above the liquid iron surface, when converter is in a horizontal position, to avoid premature Mg contact with iron. While converter is in a horizontal position (Fig. 6a), the measured amount of pure Mg is charged into reaction chamber. After loading the chamber, liquid iron is tapped into the converter through the spout having a pneumatically operated cover. The treatment occurs when the converter is tilted into vertical position (Fig. 6b). Liquid iron enters the reaction chamber through the holes and reacts with the Mg. The magnesium vapors increase pressure in the reaction chamber and pump out treated iron, promoting the intensive mixing of magnesium with the rest of the iron. The reaction rate depends on the diameter of the holes and does not exceed a couple of minutes, but the whole treatment cycle depends on the vessel capacity and varies from 15 min for a converter capacity up to 1 ton to 30 min for the capacity above 3 tons. When treatment is completed, the iron is tapped (Fig. 6c) into a pouring ladle or is transferred into a holding furnace, and the converter returns to the filling position for the next cycle. To insure safety and environmental conditions, it is recommended that the converter be operated in a properly ventilated area.

Mg-containing wire introduced into liquid iron by a special feeding device that gradually delivers wire into closed ladle. The wire is a long low carbon steel tube filled with Mg-containing alloy and other additives. The Mg alloy may contain from 9 – 92% Mg in any form. Typical treatment weights range from 500 – 27,000 kg in foundries with continuous molding lines; also, weight up to 50 tons can be treated for producers of large castings.

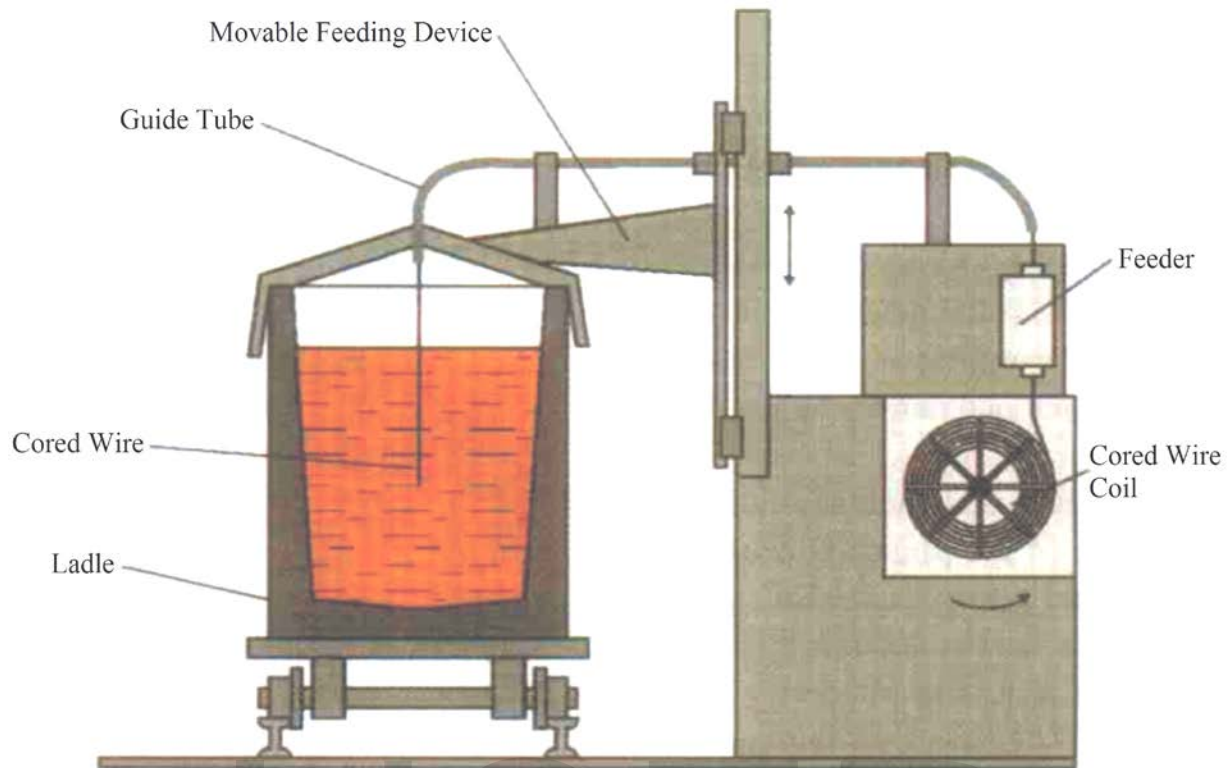

Fig. 7: A schematic diagram of cored wire process [35]

The cored wire process is an automated one, allowing precise control of residual Mg content by precise wire addition, and it is flexible with respect to capacity, base iron sulphur content, and temperature ranges. Mg recovery increases with decreasing Mg content in the wire, and it is normally in the 30 – 50% range [36]. This method can tolerate base iron containing up to 0.09% sulphur due to the use of high Mg-containing alloy. The temperature losses are relatively low; 50 – 72 °C.

As a continuous process, this method is also suitable for making ductile iron concurrently with its production on a horizontal continuous casting machine (Fig. 8).

2.2.2 Treatment methods using magnesium master alloys

Magnesium master alloys can be classified as light and heavy, depending on their density relative to liquid iron [47]. Depending on the characteristics of each master alloy, different treatment methods are used. The most commonly used light master alloys are silicon-based and heavy master alloys are nickel- or copper-based. For commercial production of ductile iron, these master alloys may contain additions of aluminum, calcium, or other rare earths. However, it should be considered that aluminum might cause pin holing in ductile iron,

and calcium causes excessive slag build-up that makes it undesirable for the holding furnace.

The Mg content is a very important characteristic of master alloys. With increasing Mg content, Mg recovery in liquid iron decreases while pyroeffect increases. Typical light FeSiMg master alloy contains 3.0 – 10.0% Mg, 43 – 48 percent Si, 0.8 – 2.0% Ca and up to 2.5% Ce. Nickel- or copper-based master alloys may contain from 5 – 15% Mg, with rest being Ni or Cu. In some cases, the nickel can be replaced by 32 – 36% Fe or 26 – 33 percent Si, with an eye toward economy.

Nickel- or copper-based master alloys have a higher density than liquid iron. This eliminates the need for special mixing to prevent the master from floating on the liquid iron surface. Nickel and copper acts as strong pearlite stabilizer and light graphitizes, minimizing variations in mechanical properties between thin and thick sections of castings. Light master alloys require the use of appropriate methods for improving Mg recovery by keeping the treatment alloy below the liquid iron surface until it is fully dissolved, thus minimizing Mg losses and reducing pyroeffect. Among these methods, the most widely used are in-ladle, in-mold, and flow-through.

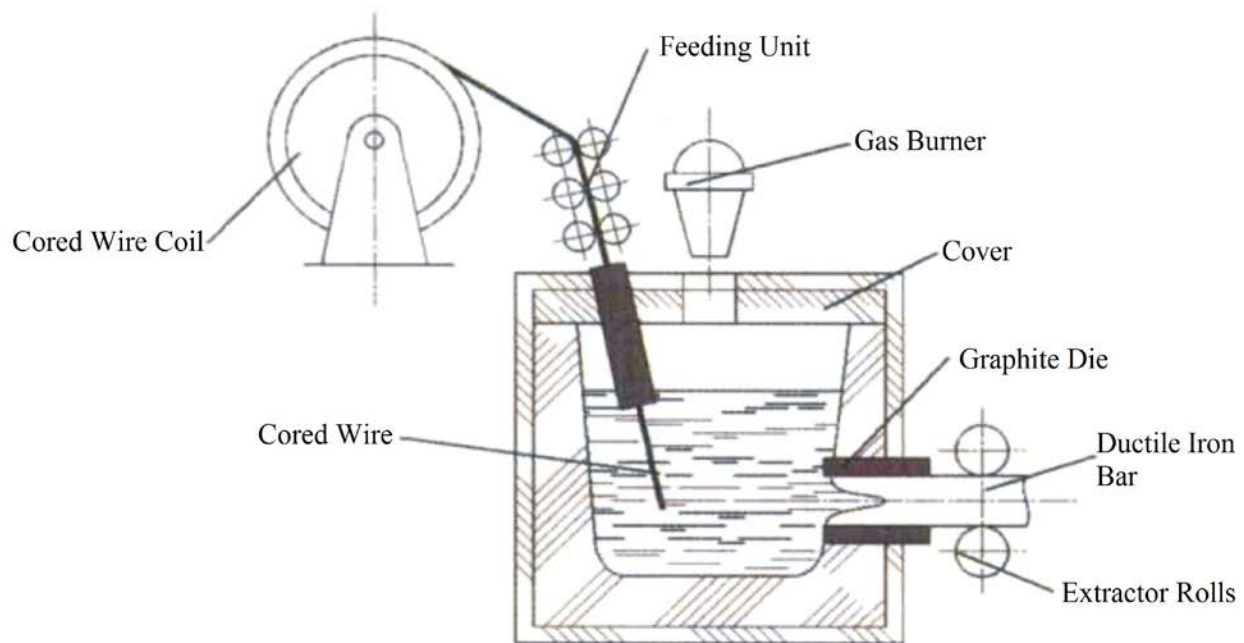

Fig. 8: A schematic diagram of cored wire treatment process used for horizontal continuous casting of ductile iron [35]

2.2.2.1 In-ladle treatment methods

A number of in-ladle treatment techniques have been developed over the years. The most common treatment techniques in use today are open ladle process, sandwich, and tundish.

Open ladle process: The open ladle process is the choice of many foundries worldwide, due to simplicity and low capital investment costs. In the case of pour over, the alloy is added into the bottom of treatment ladle and the ladle is subsequently filled. The disadvantages of the process are excessive flame and flare coupled with variable magnesium recoveries and inefficient use of the treatment alloy.

The use of a heavy Mg master alloy can help to reduce significantly the pyroeffect problems. While using heavy alloys, ladle design is not so important, nor is the filling time. Mg recovery is in the range of 50 – 70%. However, nickel and copper based master alloys are relatively expensive and are typically used to produce mostly pearlitic grades of ductile iron [36]. Otherwise, the use of heavy master alloys for treatment is cost effective. In addition, the reuse of ductile irons returns treated by heavy master alloys is limited due to possible build-up of Cu and Ni.

Sandwich process: The sandwich process is an improved modification of the open ladle process. In this process, the magnesium ferrosilicon is introduced into pocket built into the ladle and is covered with either steel punching or ferrosilicon (Fig. 9). The cover material acts as a physical barrier between the nodularizing alloy and incoming molten iron which delays reaction time therefore increases efficiency in terms of alloy use, magnesium recovery and giving a reduction in flame and flaring. The major advantages of this method are simplicity and low cost. Magnesium recovery in the range of 30 – 50%

can be achieved. The temperature losses are relatively low, and for the well-preheated ladle are about 61 – 78 °C. The sandwich process is flexible and can be used for different sizes of ladles. The disadvantages include the necessity of using low sulphur base iron, unstable magnesium recovery and relatively high pyroeffect [36].

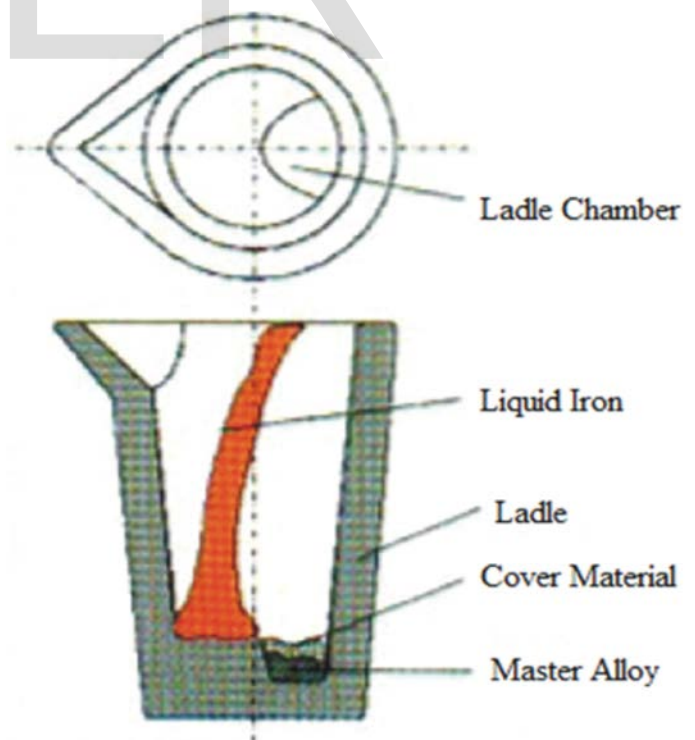

Fig. 9: A schematic diagram of sandwich process [36]

Tundish process: The tundish process is a further improvement of sandwich method and is aimed at reducing the oxygen level inside the ladle by applying a special cover. This cover is designed in the form of pouring basing (Fig. 10) with hole to fill the ladle with liquid iron and provide a constant flow rate. A special dividing wall is located at the bottom of

the ladle to separate the area with nodulizing material and is the part to be filled first in order to avoid premature master alloy dissolution. A covering material is also required, though generally in lesser quantities than used in the sandwich process.

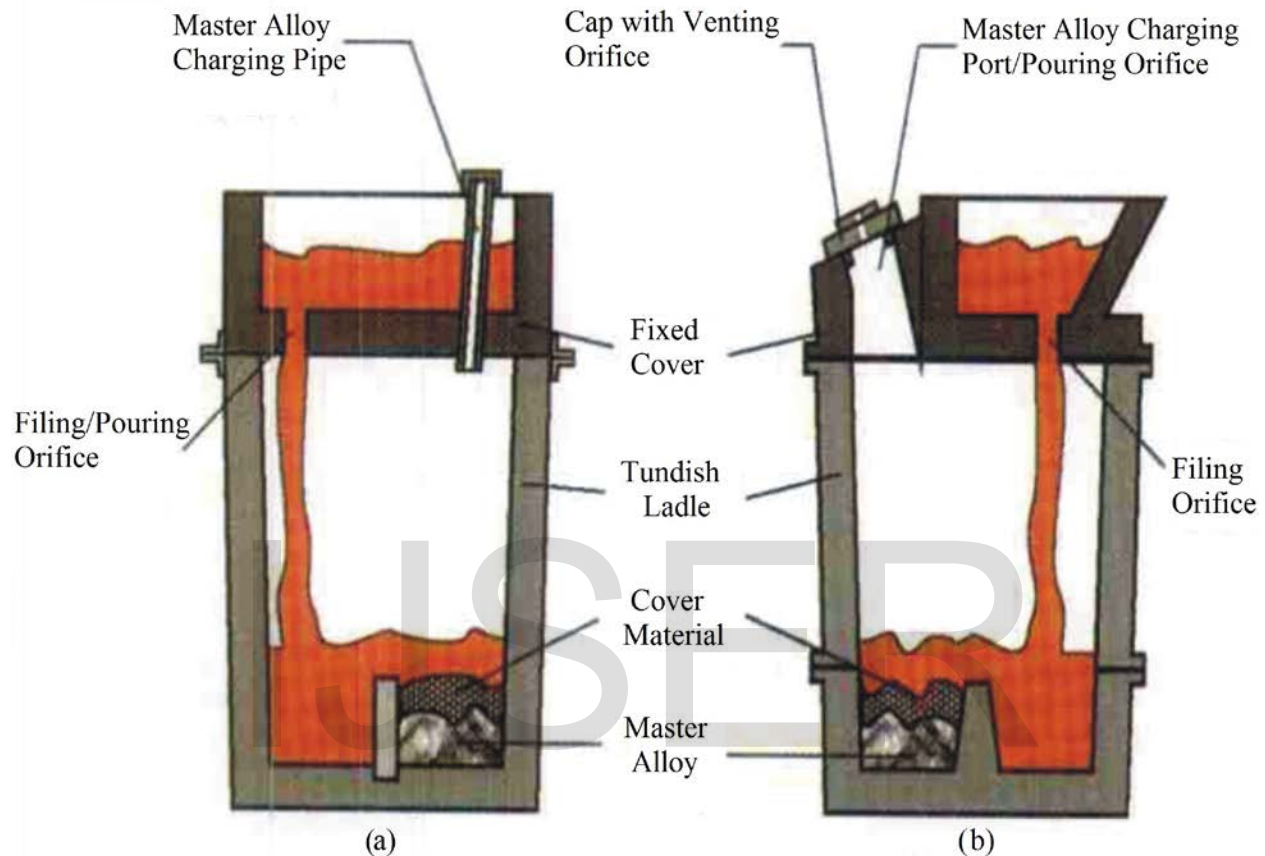

Fig. 10: Schematic diagrams of the tundish ladle with fixed cover: a) old design b) new design [36]

In the early tundish ladle designs (Fig. 10a), the treatment alloy is placed into the ladle through a special charging pipe with a removable cap. Liquid iron is poured in (and out) through the narrow orifice. However, an excessive slag build up blocked the pouring out of treated iron. In the improved tundish ladle with fixed cover design (Fig. 10b); the treatment alloy is placed into the ladle through the controlled venting

orifice, which is also used as pour out spout and deslagging port. To prevent blowback from the tundish orifice a relief valve is installed. To eliminate possible slag build up, the tundish ladle with two treatment pockets was developed as shown in Fig. 11. After each treatment cycle, the cover is rotated 180° and the energy of the falling stream helps to clean the appropriate pocket of the ladle by washing slag out.

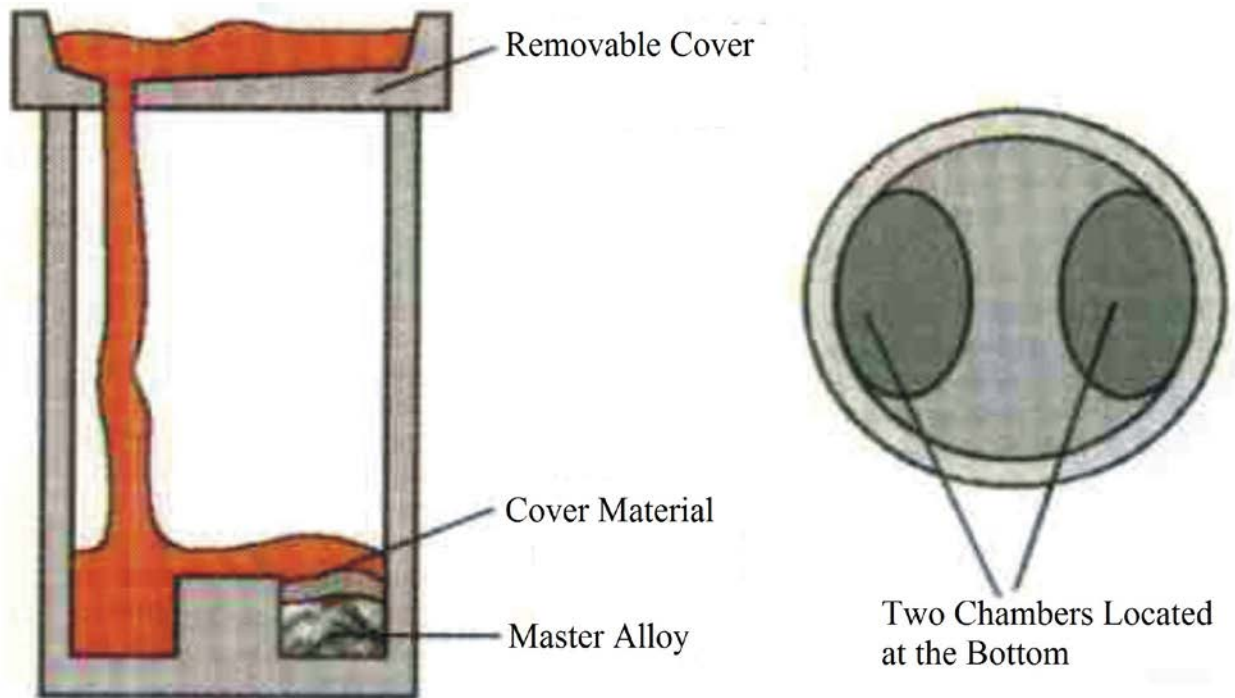

Fig. 11: A schematic diagram of two-chamber tundish ladle with removable cover [36]

Teapot tundish ladles are designed to ease slag removal. After placing the treatment alloy (Fig. 12a), the cover cap is closed, clamped, and the ladle is filled through an enlarged opening in a teapot spout, eliminating the need for pouring basin. The disadvantage of this design is that liquid iron in the

spout cannot be treated because metal is both charged and poured through the same spout. The double teapot tundish ladle (Fig. 12b) eliminates this problem, providing treatment of all iron passing through the reaction chamber.

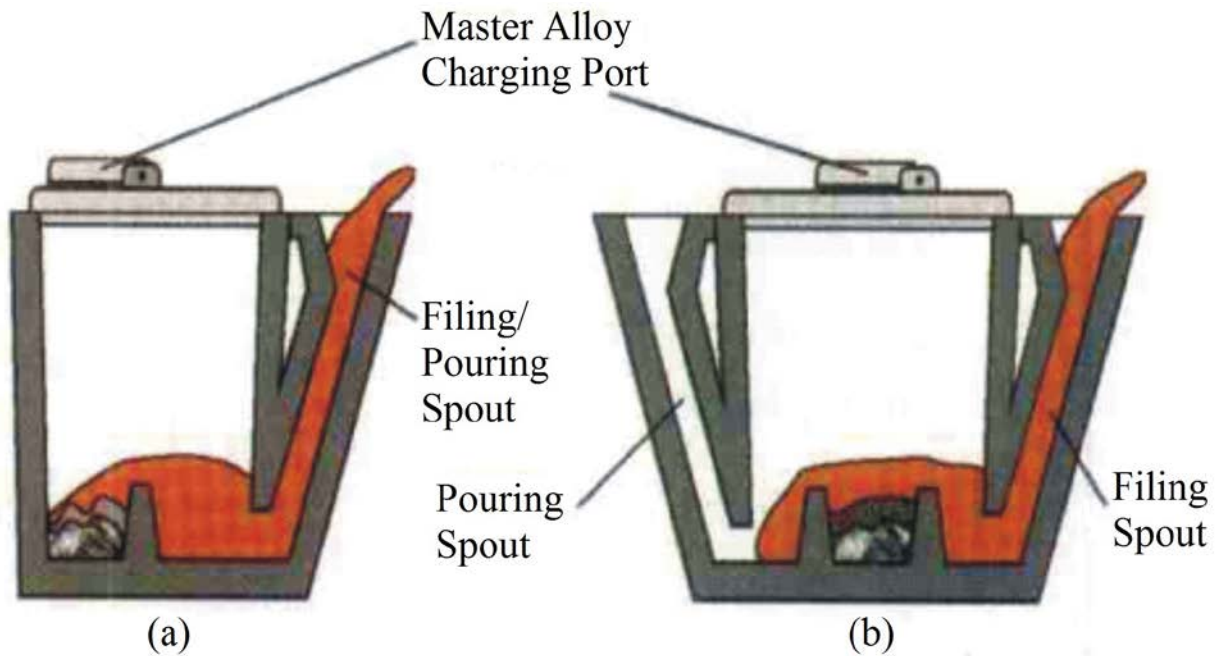

Fig. 12: Schematic diagrams of the teapot tundish ladles: a) single spout design b) double spout design [36]

The latest developments in tundish process design are aimed at improving its technical characteristics and decreasing maintenance costs. Some of these modifications have eliminated or automated cover removal during treatment cycle. The permanently fixed cover (bolted-on or wedge-clamped) solves this problem only partially. One of the latest designs utilizes the concept of the lifting cover [36].

The **tundish ladle with lifting cover** (Fig. 13) combines the accessibility of an open ladle with the advantages of tundish process, such as high Mg recovery and safety. Lifting covers can be either integrated into the ladle with a separate lifting lug or constructed as a fully removable cover. Fig. 14 illustrates a 4-position turntable arrangement of tundish process, which improves the technical, economic, and environmental aspects of the process [36].

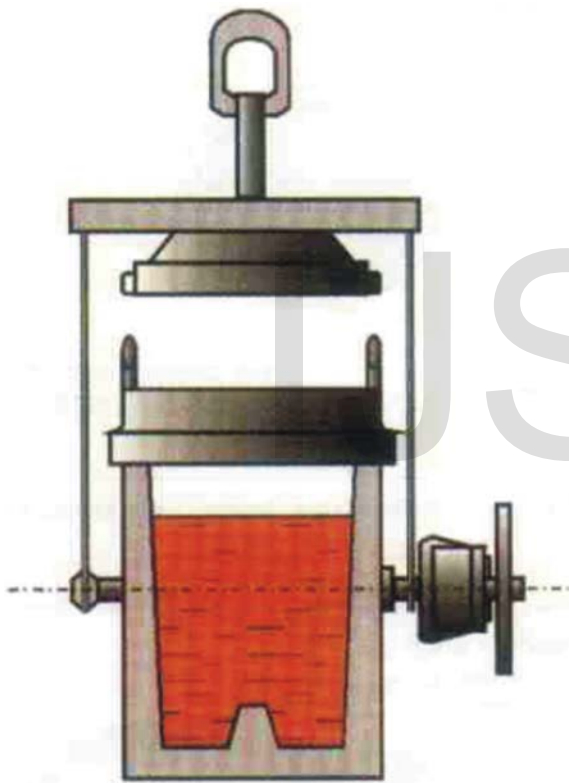

Fig. 13: A schematic diagram of the tundish ladle with lifting covers [36]

Tundish-converter (Fig. 15) is another modification of this process that is a combination of a conventional tundish ladle and Mg-treatment converter. This device contains a reaction chamber attached to the bottom of the ladle to hold pure Mg or master alloys. Liquid iron is tapped through tundish cover and then through orifices, located at the bottom, enters reaction chamber, and reacts with nodulizer loaded in the chamber before tapping. Inoculants may be added into the stream during tapping into pouring ladle or during the pouring of

moulds. A crane or monorail delivery system allows the use of tundish-converter as a transfer ladle to tap ductile iron into pouring ladle or auto pour.

According to the designers and users of this unit, low capital expenses and simplicity in maintenance along with relatively high Mg recovery, combined with advantages of using the pure Mg process, made the tundish-converter a cost effective alternative to more complicated Mg-treatment devices [36]. The advantages of this technique are the reasons that 30% of the world's ductile iron is currently produced by this method. Mg recovery in the tundish process may reach up to 75%. The low cost of tundish ladles is accompanied with high environmental safety. Using FeSiMg master alloys containing 5 – 7% Mg, it is possible to operate these ladles without venting. Finally, iron treated in tundish ladles processes is easily inoculated. A few disadvantages are related to dislagging, requiring less than 0.02% sulphur content in the iron to minimize slag build-up. The temperature loss varies from 69 – 100 °C, depending upon ladle capacity. The amount of charging iron should be controlled due to inability to visually check the ladle filling.

2.2.2.2 In-mold treatment methods

With the in-mould process (Fig. 16), the FeSiMg master alloy with 3 – 5% Mg content is placed into reaction chamber of each mould during mold assembly. Liquid iron is treated by passing it over the reaction chamber that is a part of running system of the mold. All parameters of this process, such as the temperature and flow rate of liquid iron, the geometry of the reaction chamber and gating system, and the size and type of master alloy must be predetermined and strictly controlled in order to yield successful treatment.

Since the in-mould inoculation using a reaction chamber became conventional practice in foundries, the latest developments have aimed at improving this method. Some inventions describe the reaction chamber located directly in a pouring basin. Inoculants are placed into pouring basin. In US patent 4779668 (General Motors Corp), two reaction chambers are located in the pouring basing opposite the sprue hole as shown in Fig. 17 [43]. A removable refractory cover plate breaks the metal flow into two streams, each of which enters into a gap between the cover plate and the basin wall and reacts with the treatment alloy in the reaction chamber. The treated streams then flow under the cover plate to prevent its displacement during pouring. US patent 5390723 describes another method, where the reaction chamber is located in a pouring basin [44]. Treatment alloy is placed into the reaction chamber before pouring, the outlet of which is closed by a consumable plug assembly (Fig. 18). The consumable plug has pre-defined chemical and physical characteristics to provide the required time for holding the molten metal above the reaction chamber before entering the sprue.

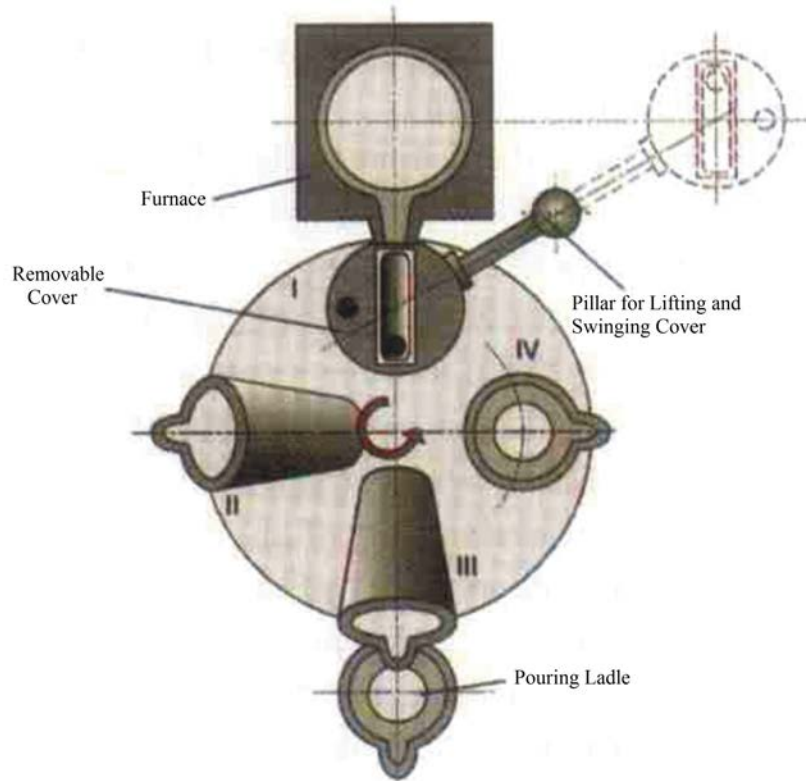

Fig. 14: A schematic diagram of tundish-converter for Mg-treatment of iron [36]

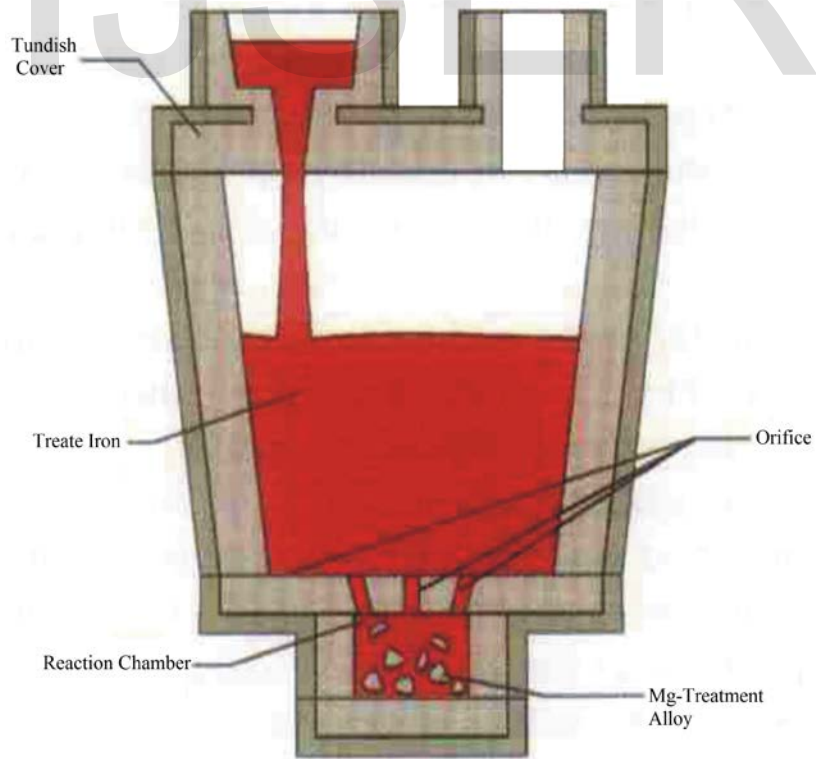

Fig. 15: A schematic diagram of tundish-converter for Mg-treatment of iron [36]

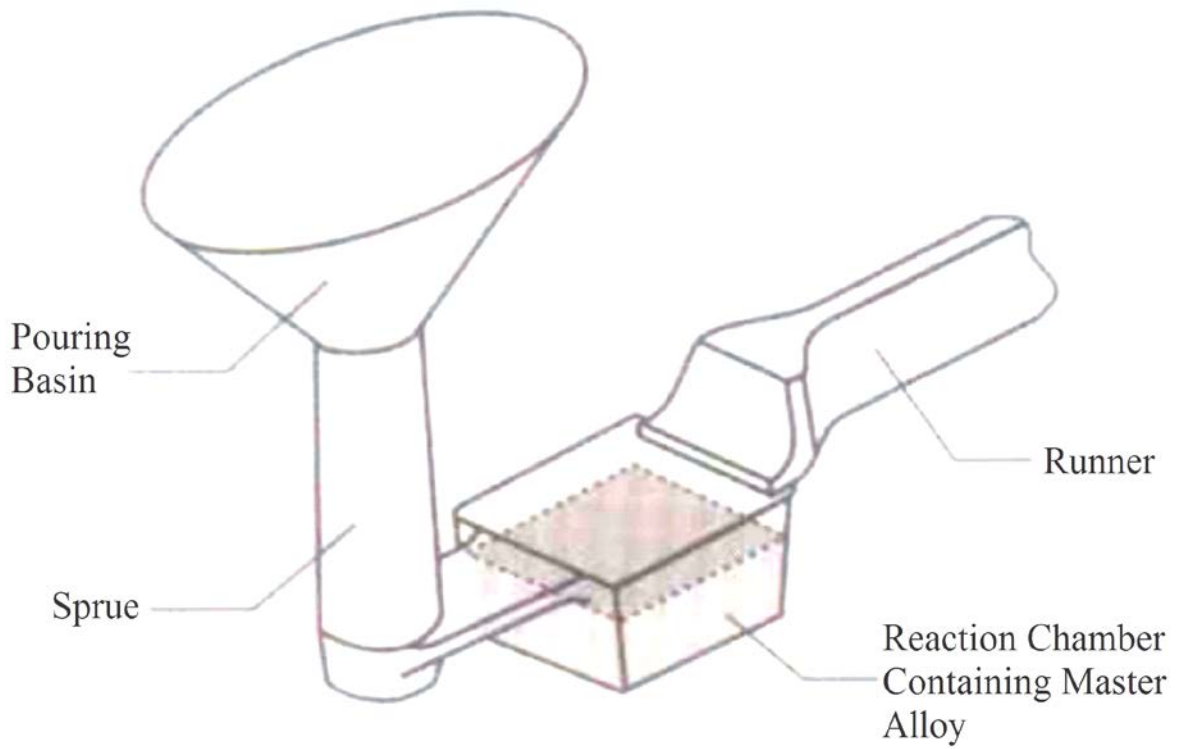

Fig. 16: A schematic diagram of in-mold process [36]

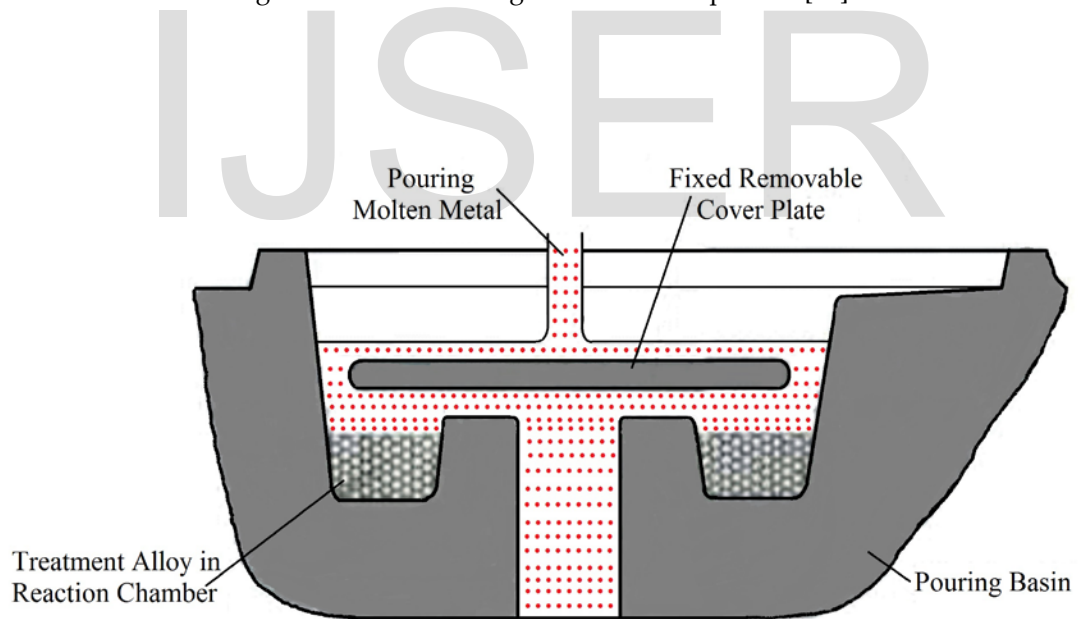

Fig. 17: The pouring basin containing two reaction chambers [46]

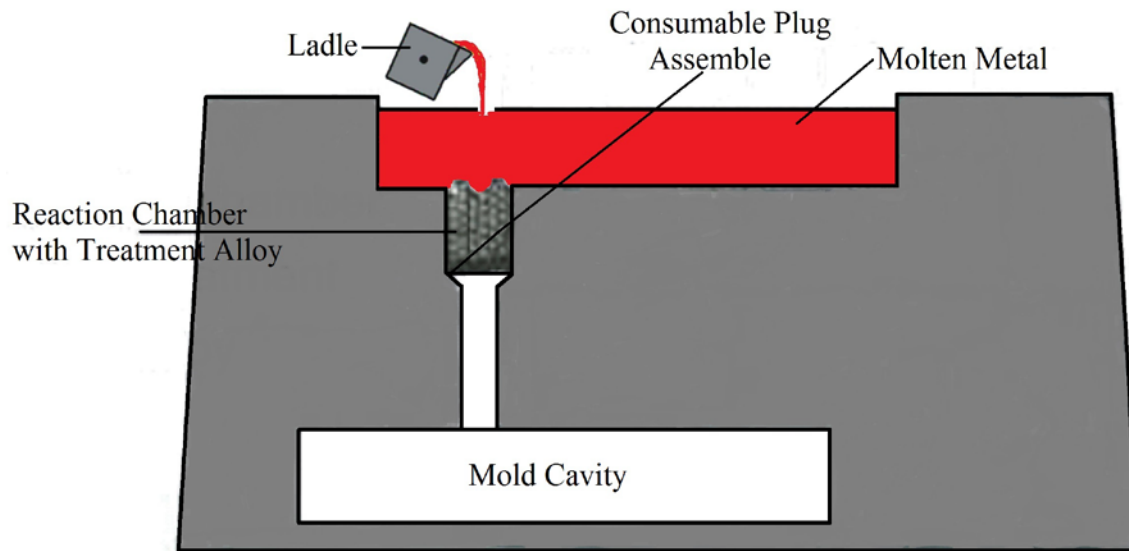

Fig. 18: Reaction chamber containing treatment and located in a pouring basin [46]

Another possible solution utilizing the pouring basin as a reaction chamber is shown in Fig. 19, where an inoculant block of cylindrical or cubic shape is either anchored (a) into pouring basin or floated (b) in it. A slag trap serves to prevent entering of slag and undissolved particles into the sprue. In case of a floating block of inoculant, the slag trap also prevents it falling

into the sprue. If a large quantity of molten metal is being poured in the mold, a stopper can be applied. This allows holding the liquid metal in the basin for the time needed for inoculation dissolution and its better distribution through the metal. Gradual dissolution of inoculants ensures effective late inoculation of iron.

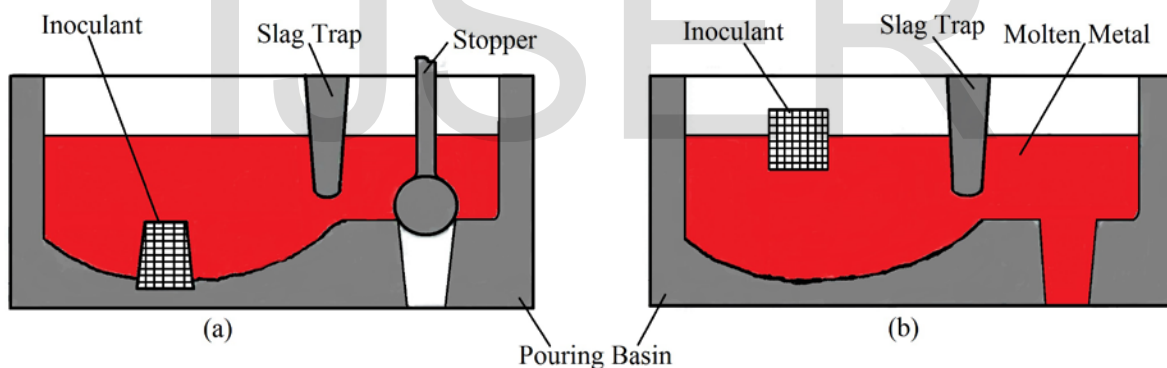

Fig. 19: Pouring basin with anchored (a) and filtration (b) inoculants block [46]

A number of methods employ the compacted inoculants blocks of a pre-determined shape placed in the molten metal flow, thus allowing the reaction chamber to be avoided which resulted to improvement in inoculation effect. According to the Japanese patent 59137155A2 (Toshiba Corp), cylindrical shaped inoculants having a through hole is placed in the sprue, where the through hole axis is coaxial with sprue direction [40]. During the time of pouring, the molten metal makes contact with the inside wall of the inoculants and dissolves it (Fig. 20). The efficiency of inoculation depends on the diameter of the inoculants through hole, as well as of pouring rate, metal temperature, and type of inoculants.

US patent 4867227 (Metallgesellschaft Aktiengesellschaft, Frankfurt, Germany) utilizes the same idea, although the in-

oculants block is placed across the sprue and fixed in two opposite recesses [48]. The flow area has pre-determined air gap between inoculants and sprue walls and repeats the inoculants block configuration to improve inoculating effect. The shape of the inoculants block and recesses can vary, one typical design being shown in Fig. 21.

Inoculants placed into the reaction container was developed in order to simplify mould constructions and to improve inoculation result stability. Japanese patent 62185859A2 (Kubota Ltd) describes the reaction chamber placed into sprue and made like a container with two caps, which act as filter, Fig. 22 [41]. The coreless body of the vessel is made from cylindrical foil formed from refractory material. The pre-weigh inoculant is placed inside the container. During pouring of molten iron,

the undesirable inclusions such as slag, dross, and sand clusters are removed by the first upper filter cap, and next, the second filter cap removes the reaction products.

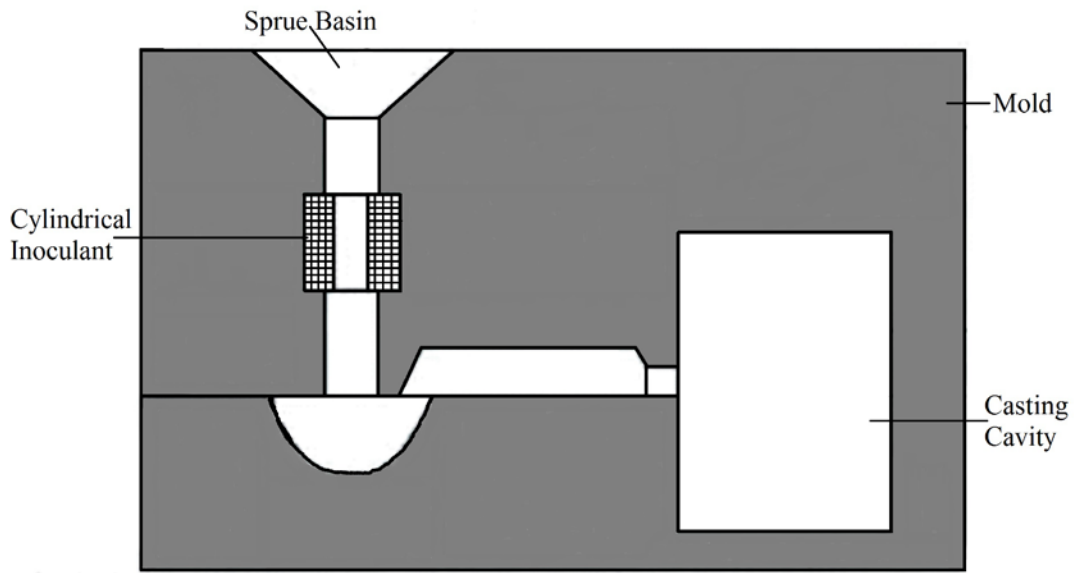

Fig. 20: Hollow cylindrical inoculants located in the sprue [46]

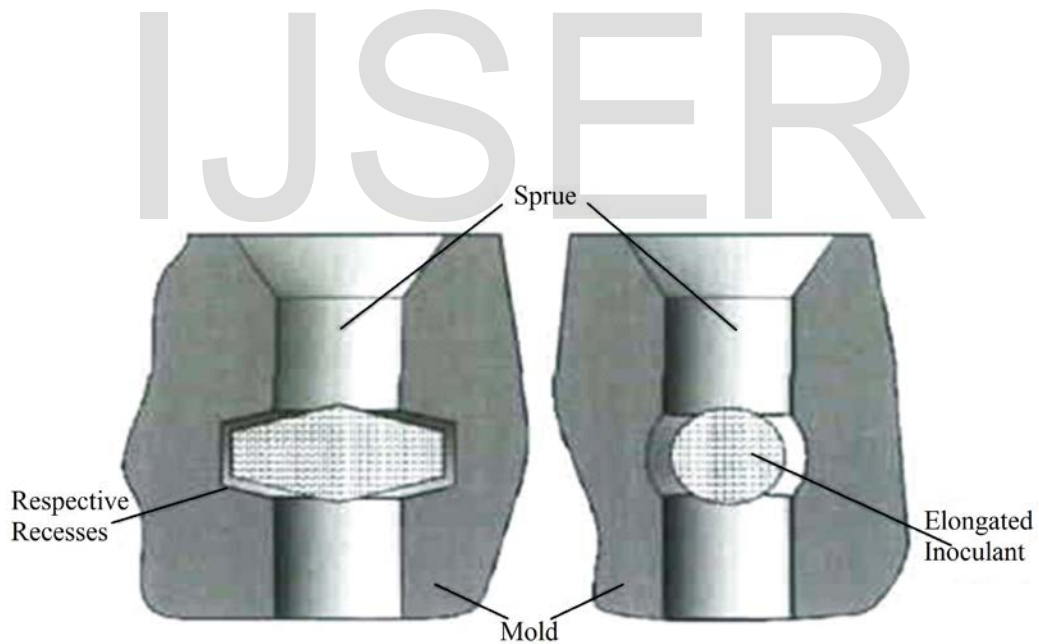

Figure 21: A vertical sectional view through a sprue of a mold [46]

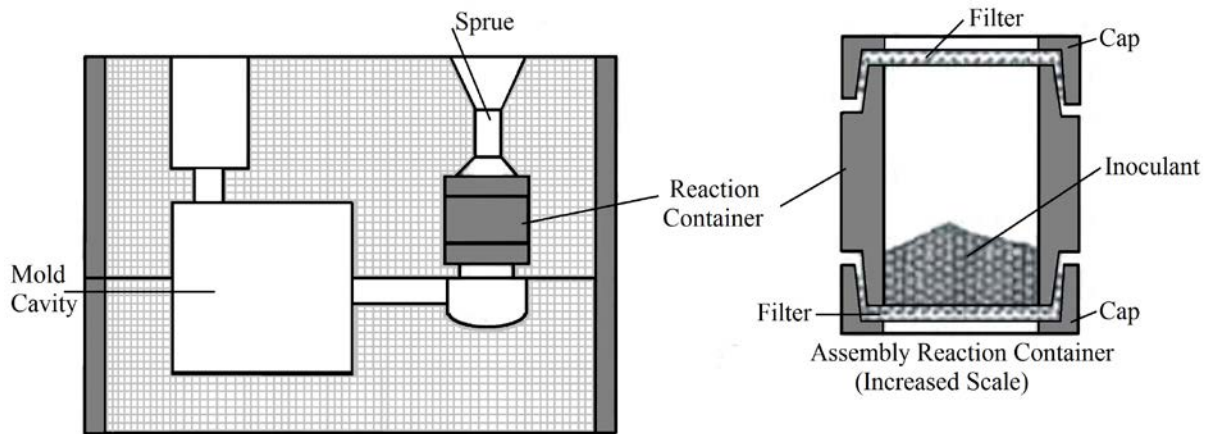

Fig. 22: Reaction container in in-mold inoculation [46]

A new design of the reaction chamber is made like elongated sprue well and can be shifted to compensate the different weight of the pouring parts, shown in Fig. 23. It was claimed that this placement achieves improved casting yield, better mold utilization and standardization of the gating system [36]. For better results, a large, effective sprue height is recommended to achieve a fast and uniform pouring rate across the alloy. The optimal runner designs require that they should be wide and flat, located in the cope wherever possible and in one plane, and be vented. To improve the inoculants dissolution and recovery rate, Japanese patent 57025249A2 (Hitachi Zosen Corp) suggests using electromagnets as shown in Fig. 24 [39].

Inoculants sprayed into the mould cavity is claimed by Japanese patent 57160566A2 (Komatsu, Ltd) for treating the surface area inside the mould before pouring [38]. It is especially recommended for thin wall casting as shown in Fig. 25. Molten metal, which was not inoculated before, fills the mould cavity and reacts with sprayed silicon base inoculants.

The in-mold process allows Mg recoveries of 70 – 80%, providing effective inoculation because iron is treated directly in the mould before solidification. Temperature losses are minimized, as is pyroeffect. The in-mold process, in combination with automated holding-pouring systems, is popular in the mass production of automotive parts. Approximately 10 percent of all ductile iron is produced by this process.

The high risk of impurities in the castings is a major disadvantage of this process. To reduce slag build-up and its penetration into castings, extremely low sulphur iron must be used (less than 0.01%), and an in-mold filtration is recommended. Because each mold is a discrete treatment process, it must be considered as a bath or heat and require special quality control procedure to check for nodularity, especially in safety parts.

The latest developments in in-mold inoculation techniques are attempted to place inoculants inside the filter [40]. Using this technique practically eliminates chill due to preventing fading of inoculants, simultaneously providing effective filtration,

which improves mechanical properties and machinability. It also allows the production cycle to be reduced and automated, and as a result, reduces operation costs.

The traditional in-mold technology has been in used over years to produce ductile iron. It is based on positioning a reaction chamber in each mold. The magnesium alloy is placed in the chamber, which is connected to the gating system. The mold is poured with “untreated” base iron. When the iron flows over the alloy in the reaction chamber it picks up magnesium. The treatment is thus inside the mold – hence the name in-mold. When ductile iron is to be produced it is enough to ensure that the metal picks up more than 0.035% Mg. This can easily be achieved with the traditional in-mold system. However, if one tries to use the same concept to produce compacted graphite iron (CGI) it will fail, because with the traditional system it is not possible to control the flow over the chamber with sufficient accuracy to achieve the very narrow process needed (e.g. $0.008 > \text{Mg} < 0.01\%$). Another source for process variations is that the traditional system relies on chemical analysis alone to control the base iron.

NovaCast has modified the traditional in-mold system to fulfill the stringent requirements for production of compacted graphite iron. The novel approach, called NovaCast PQ-CGI in-mold process (Fig. 26), has been developed using NovaCast’s fluid flow simulating software NovaFlow, its metallurgical process control technology and expert systems methodology.

The PQ-CGI in-mold process is based on a stringent control of the oxygen level and the nucleation status of the base iron (patents pending). This is achieved using the PQ-CGI system, which is based on advanced thermal analysis. Two small samples (Quik-Cups) are poured when testing the base iron. One of them contains deoxidant. The PQ-CGI software evaluates the samples and estimates the thermal properties of the melt as well as the total amount of oxygen. The information is evaluated by the system, which recommends which conditioners must be added to the melt. These conditioners, which are

normally added to the ladle, are used to fine-tune the base iron. The gating system has a novel design (patents pending) to control the flow in the reaction chamber and to achieve an even magnesium level in the iron during the whole pouring cycle. Using fluid flow simulation and specific design rules, the reaction chamber and gating system are optimized for

each casting pattern. This novel approach has been proven to overcome the limitations associated with the traditional system [49]. The PQ-CGI in-mould system can also be applied in a specially designed pouring ladle if the mold does not have enough space for a reaction chamber.

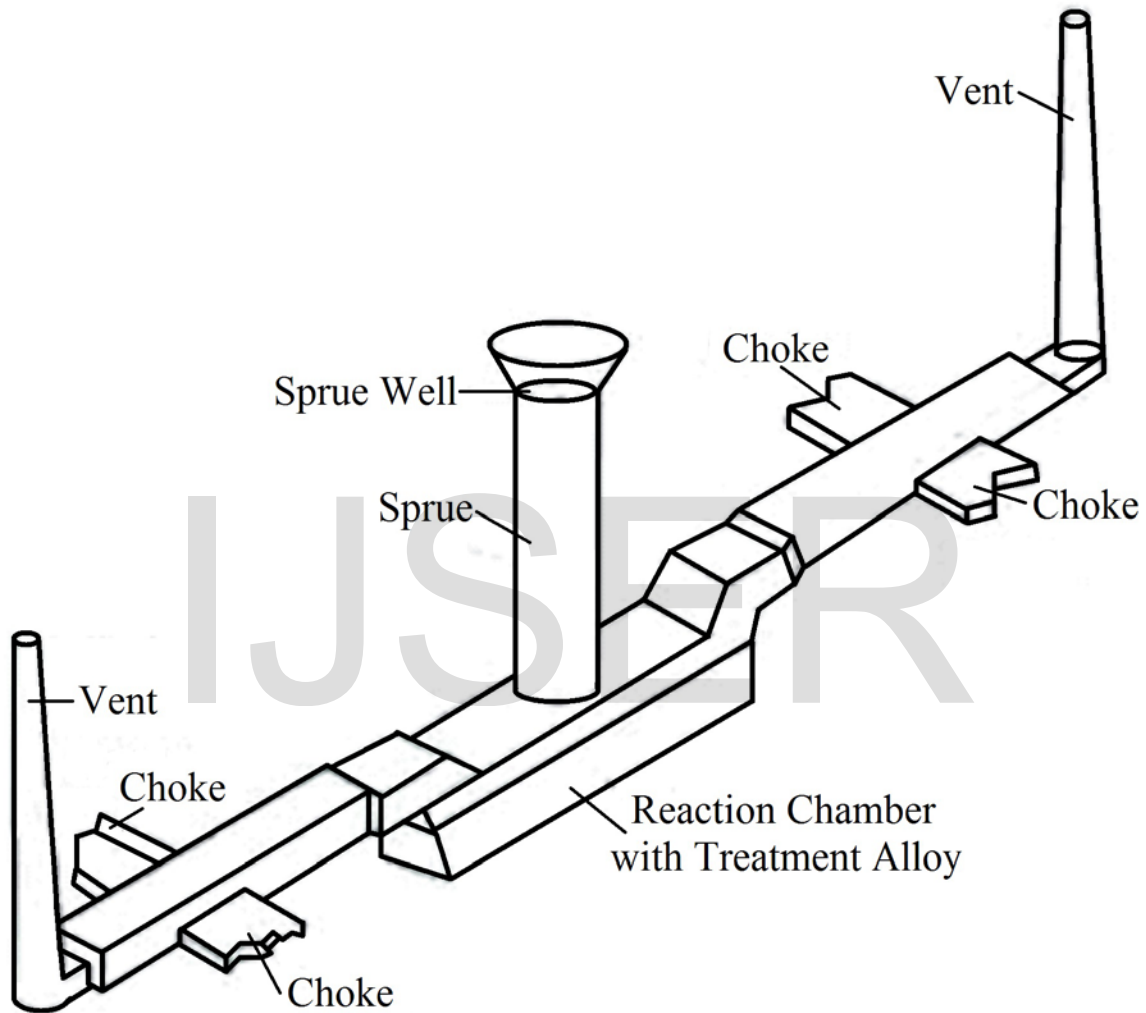

Fig. 23: A mold reaction chamber in the form of elongated sprue well [46]

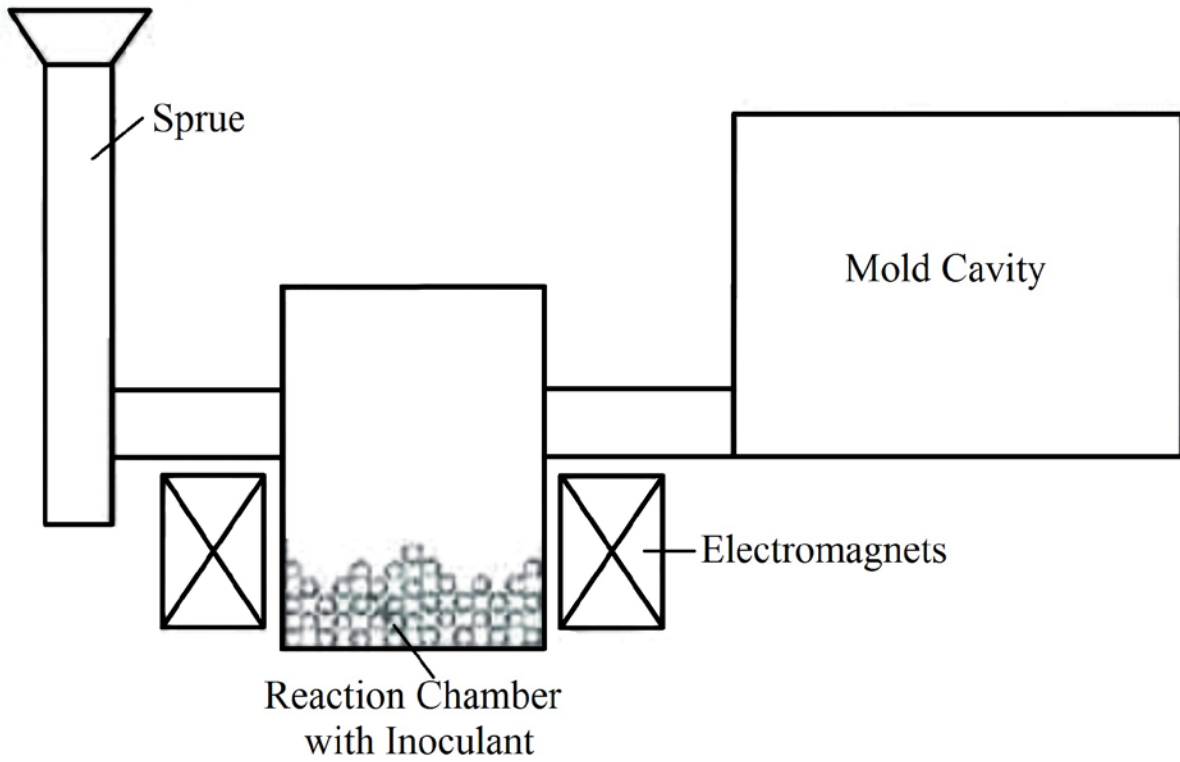

Fig. 24: A Schematic diagram of an inoculation process utilizing electromagnetic force [46]

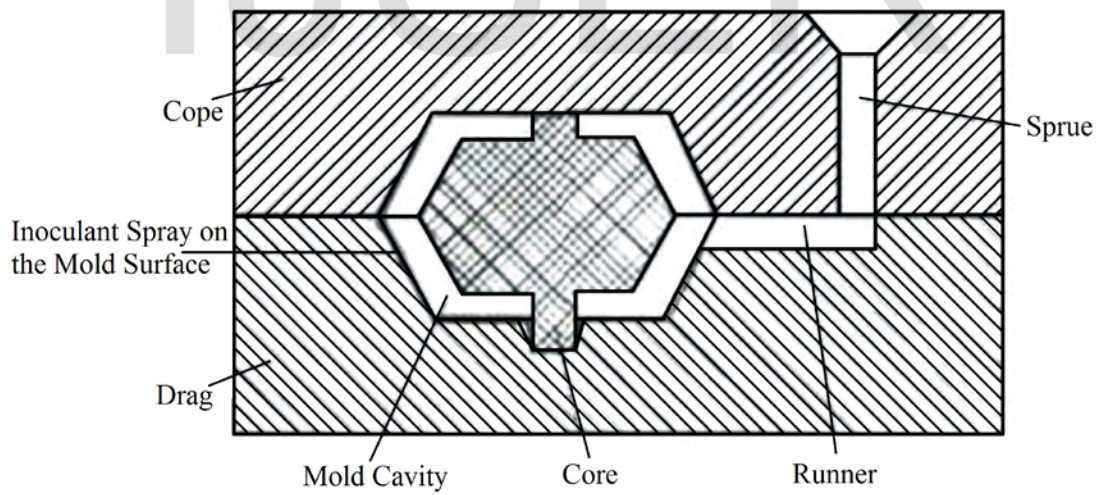

Fig. 25: Silicon based inoculants sprayed on the mold walls [46]

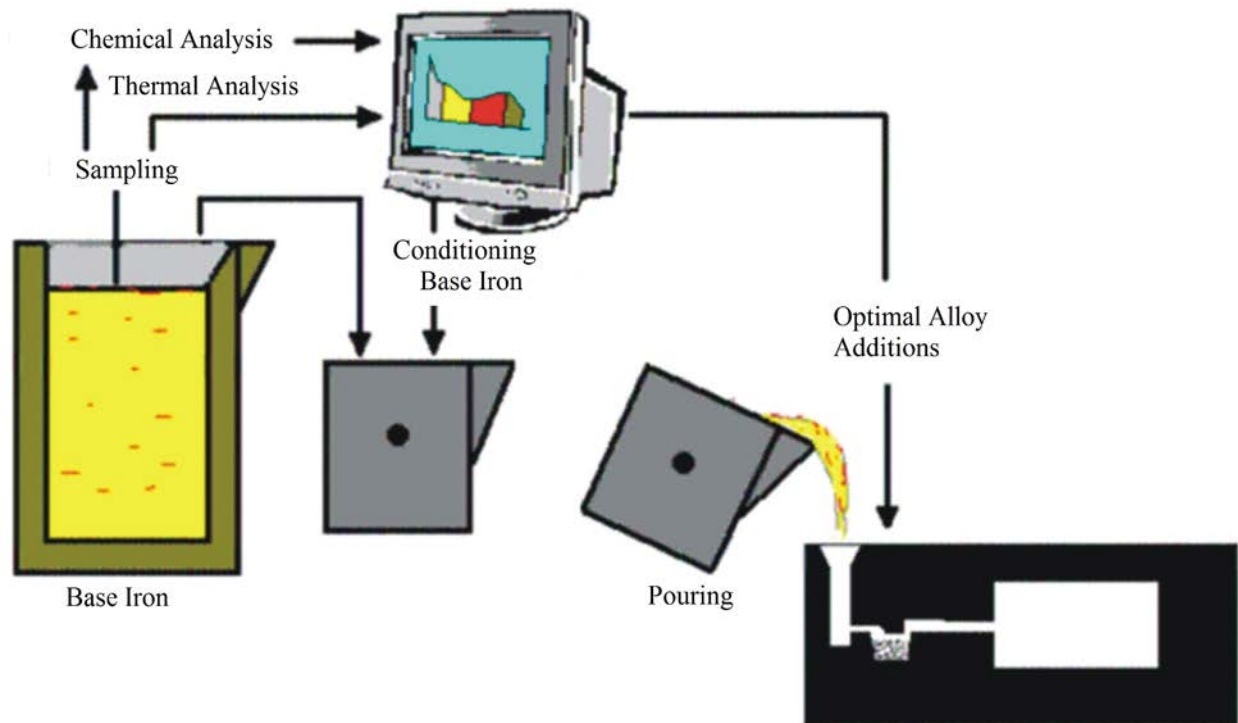

Fig. 26: A schematic diagram of the NoveCast PQ in-mold method [49]

2.2.2.3 Flow through treatment process

This method is virtually a modification of the in-mold process and employs a special reaction chamber, which is external in regard to ladles or molds. There are several types of chamber designs, but all of them employ the same idea of dynamic passing of liquid iron through the treatment chamber containing MgFeSi master alloy.

Fig. 27 illustrates an example of a flow through treatment device design. This unit is located between the source of liquid iron, such as coreless induction furnace, and target ladle such as the transfer ladle. Magnesium containing master alloy is charged into the reaction chamber through the charging orifice, which is further sealed limiting an access to oxygen. Liquid iron is tapped into pouring basin, fills the reaction chamber containing master alloy, and treated while it passes through the reaction chamber by gradually involving and dissolving particles of master alloy. The diameter of output orifice controls the iron flow, which is very important to achieve the best results. The master alloys containing 3 – 6% Mg are typically used to reduce the reaction violence. The use of base iron with very low sulphur content (less than 0.02%) minimizes the amount of slag and improves magnesium recovery [43]. Inoculant may be added into reaction chamber or into the ladle.

This process has certain advantages such as relatively high magnesium recovery (60-70%) and the absence of smoke which eliminates the necessity of ventilation system. The de-

vice is not expensive, but highly productive; allowing treating one ton of iron in 1 - 1.5 minutes. Depending on the treatment bath, the temperature losses may vary from low to sensible level of 125 °C - 57.2 °C. This device requires minimum maintenance, mostly deslagging of pouring basin and reaction chamber.

With a number of advantages, keeping the sulphur content on the pre-determined low level might be a disadvantage. In addition, the need of using master alloy with low magnesium content increases its total consumption, which may negatively affect the overall economics.

2.2.2.4 Porous plug process

Porous plug process (Fig. 28) is based on intensive stirring of liquid iron and FeSiMg master alloy by introduction of inert gas, usually nitrogen, through a porous plug in the bottom of the ladle. Low magnesium alloy is added on the top of circulating iron mixed between 15 – 30 seconds; the inoculants can also be added in the last few seconds of the bubbling cycle.

Low cost and possibility of performing the desulphurization of high sulphur iron as well as its nodularization in the same bath during one treatment cycle makes this process suitable for foundries using cupola. The major disadvantages include low magnesium recovery, which typically does not exceed 35%, due to excessive bubbling that promotes magnesium oxidation, and temperature losses associated primarily with bubbling. Currently, only approximately 5% of ductile iron is produced by this process [36].

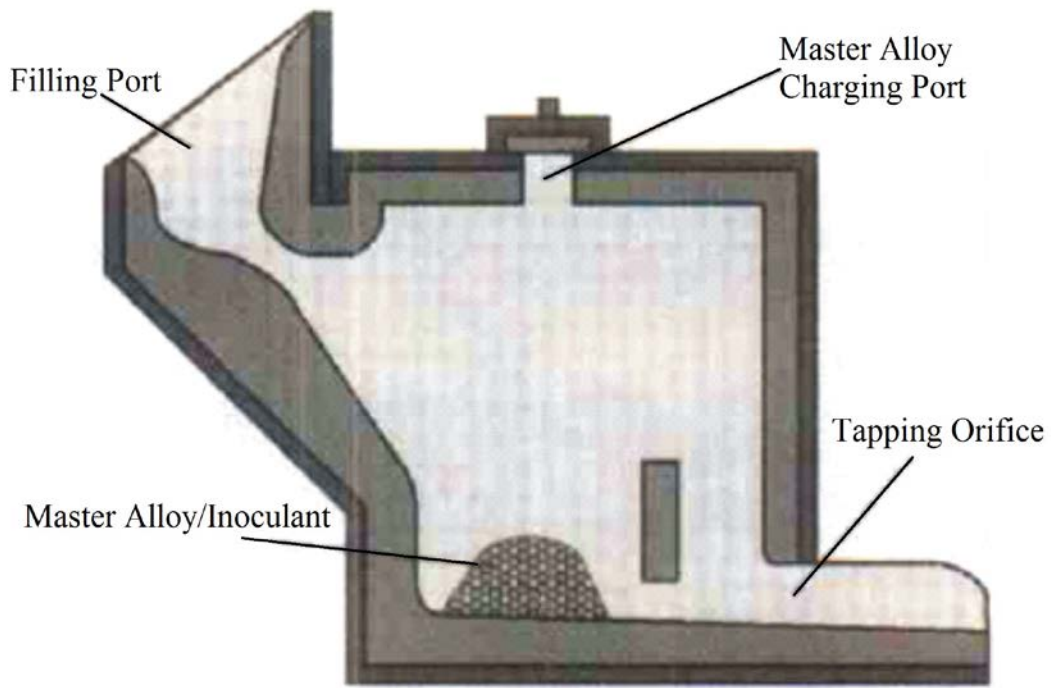

Fig. 27: Flow through magnesium treatment process [36]

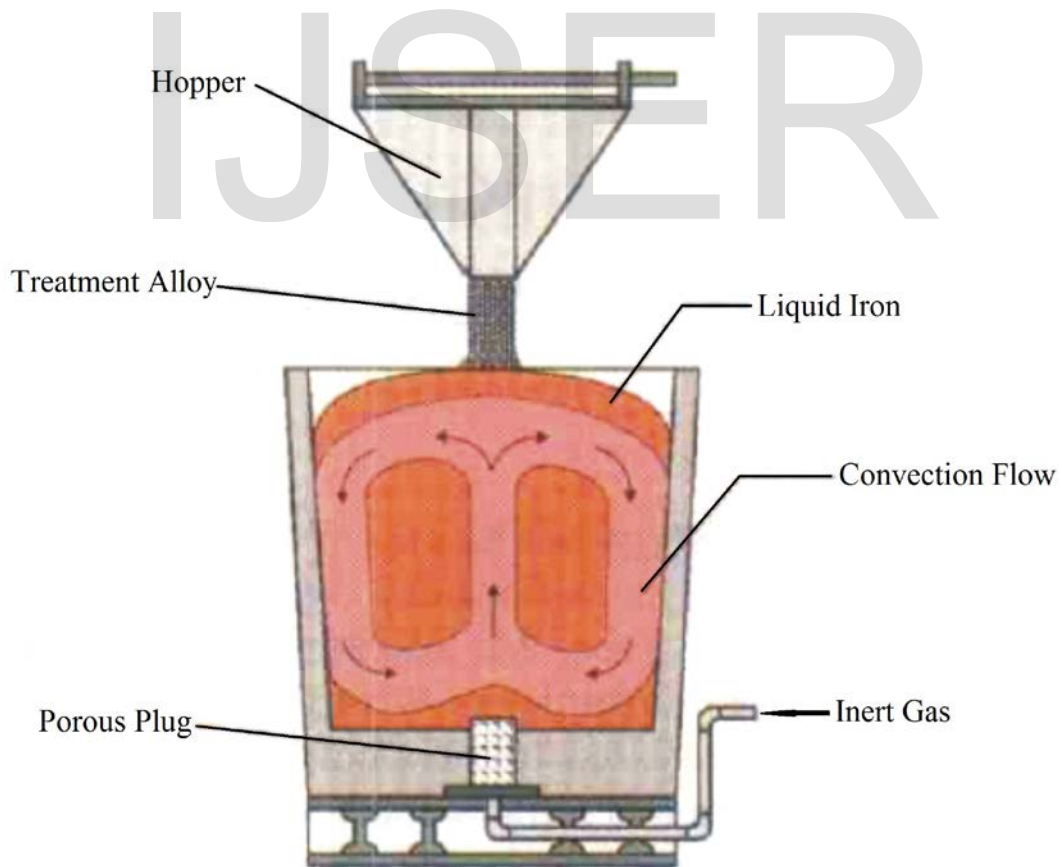

Figure 28: A schematic diagram of porous plug process [36]

2.2.2.5 Porous plug process

Several technical methods have been developed by different companies. Japanese patent 62056510A (Fig. 29) illustrates the classical combination of filtration technique and reaction chamber where a granular inoculants is located in a runner system and a ceramic filter is placed immediately after reaction chamber to prevent non-metallic inclusion entering the

casting [36]. Inoculants can also be placed directly on the top of the filter as recommended by another Japanese patent 4009265A2, Mitsubishi Motors Corporation [42]. In this case, the lumped inoculants is placed on the ceramic filter as shown in Fig. 30, allowing the classical reaction chamber to be eliminated and a decrease in mold size.

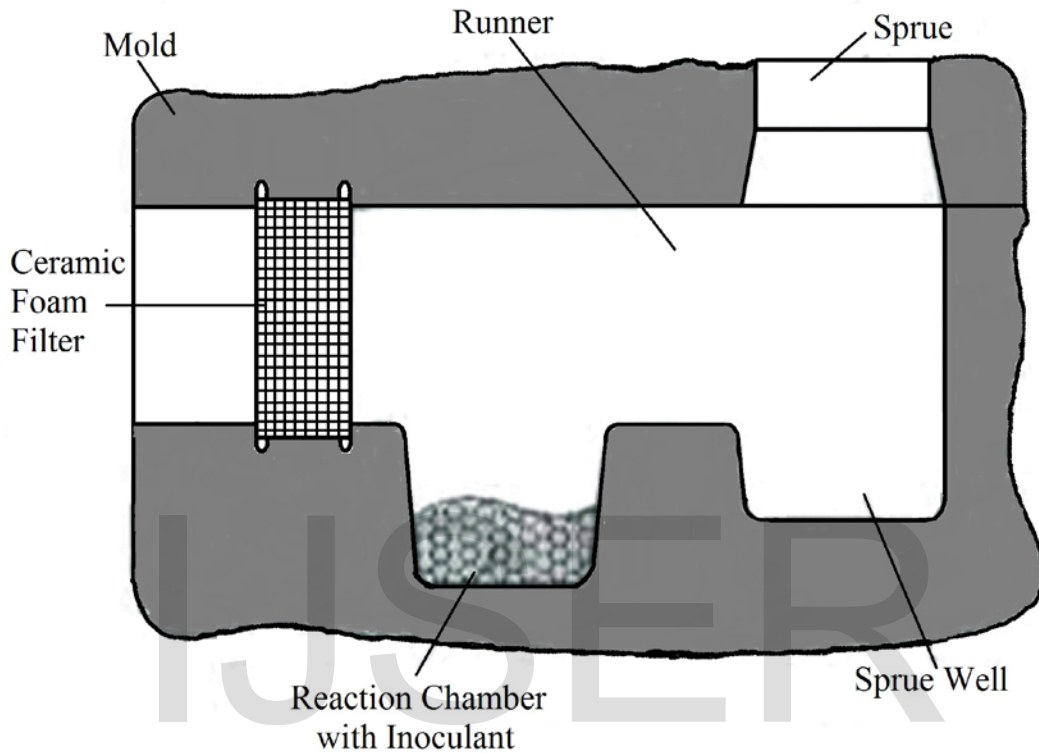

Fig. 29: A schematic diagram of in-mold process employing ceramic filter for slag trapping [36]

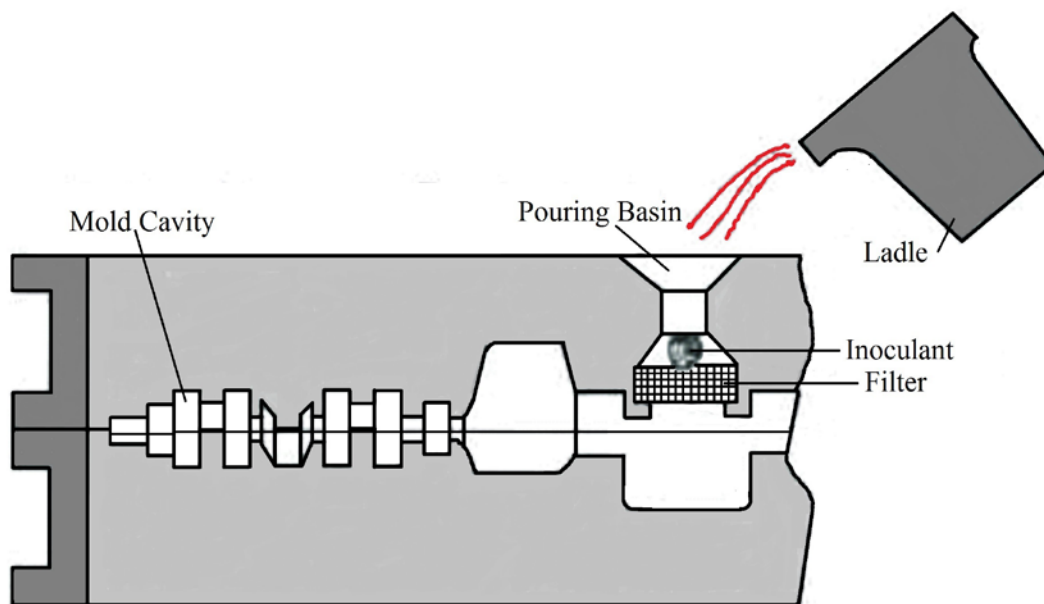

Fig. 30: In-mold inoculation and filtration: inoculant is placed on the surface of filter [46]

The fundamental of the horizontal continuous casting process (HCC) is illustrated in Fig. 31 [50]. The molten iron, with correct chemical composition and temperature, is poured into a holding furnace, and then solidified in a crystallizer installed under the holding furnace. The solidification shell forms and is stepped forward to ensure that the shell is not broken-out and the molten iron is not leaked out by means of starting traction machine. The molten iron continuously enters into the crystallizer under the gravity force and solidifies in crystallizer. Ductile iron is fabricated by the repeated operation. Diversified products with various structures are manufactured by cutting and shearing. The shaping characteristic of the continuous ductile iron casting process is at the application of the

close-style crystallizer, where the molten iron can effectively be prevented from getting contaminant with slag and sand. Since molten iron flows into the crystallizer through the bottom portion of the holding furnace, the casting defects that frequently formed in ordinary sand-castings, such as blowhole and slag spot, cannot be formed. The shrinkage and porosity are difficult to form because the molten iron in the crystallizer solidifies under high static pressure. High casting yield of 92 – 95% can be achieved since it eliminates traditional feeder needs due to the fact that molten metal in the receiver plays the role of a pre-heated riser that continuously supplies liquid metal to feed the bar during solidification and also compensate for shrinkage.

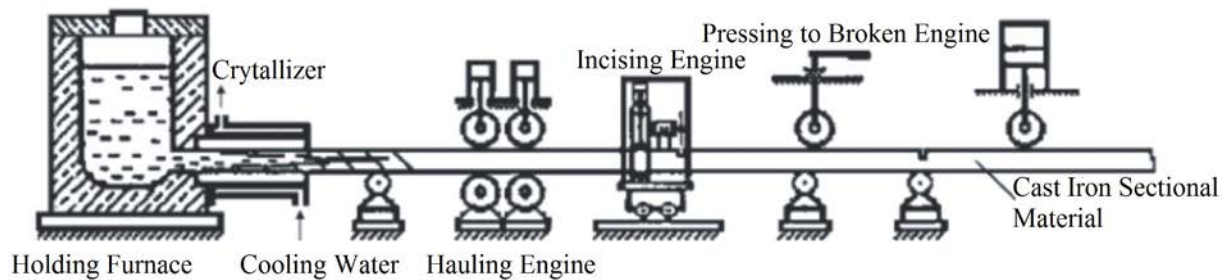

Fig. 31: A Schematic view of horizontal continuous casting (HCC) process [50]

Due to high cooling rate and nucleating rate, the nodular graphite with small diameter, soundness microstructure and good properties can be obtained in shape ductile iron by means of horizontal continuous casting. The ductile iron produced by this process is widely used in casting components such as the bushings for high-speed trains, small gear, high pressure hydraulic valve and other important components.

3 APILICATIONS OF DUCTILE IRON

Ductile iron is also available in continuously cast bar stock and can be a direct replacement for carbon steel bars in a number of gears in the automotive, hydraulic, machine tool, and other industries. Machinability advantages of continuously cast ductile iron bars over carbon steel bars are the primary reason for its growth during the past 40 years. Improved tool life and faster cycle times mean more parts produced per hour and less cost for consumable items such as machine tool inserts. Ductile iron contains precipitated graphite nodules acting as natural chip-breakers, causing less friction of the chip on the insert and allowing for a larger depth of cut because of the reduced forces required during machining [51].

The presence of graphite nodules offers additional benefits. Noise and vibration is reduced because of the damping properties of graphite, a key consideration in gear applications, and wear resistance is also improved. Ductile iron is less dense than steel, and the same parts made from ductile iron will weigh 10 percent less than if they were made of steel [52].

Ductile iron is characterized by having all of its graphite occurs in microscopic spheroids. Although this graphite constitutes about 10% by volume of ductile iron, its compact spherical shape minimizes the effect on mechanical properties and results in a structure that is ductile rather than brittle, as is the case with normal flake graphite cast irons. This ductility has produced a cast iron which can perform in areas which previously had been limited to aluminium or cast and forged steel, often at lower cost. It also has superior corrosion resistance compared to mild steel. One area of high usage is in pipes and flanges for water pumping where its low cost and good corrosion resistance gives advantages over steel pipe.

Another area where ductile iron has been used extensively is in the automotive industry where it can provide high strength and low cost alternatives to aluminium. Ductile iron is specifically useful in many automotive components, where strength needs surpass that of aluminium but do not necessarily require steel. Automotive gears, for example, are being converted to ductile iron for its damping capacity and cost reductions. Ductile iron bar stock conversions are also prevalent in many fluid power applications, including glands and rod guides, cylinders, hydrostatic transmission barrels, and in high-pressure manifolds. Both gray and ductile iron has been used for years in the machine tool industry because of their performance in sliding wear applications and vibration damping. Other major industrial applications include off-highway diesel trucks, agricultural tractors and oil well pumps. In wind power industry nodular cast iron is used for hubs and struc-

tural parts like machine frames. Nodular cast iron is suitable for large and complex shapes and high (fatigue) loads.

The relatively low cost of ductile cast iron along with the ability to produce highly complex shapes has led to its use in decorative and architectural castings such as street furniture, lamp posts, seating, fountains, floor grates and railings. It is also suitable for a wide range of component weights from a few grams to hundreds of tonnes and in quantities from one off to thousands off. A wide range of replacement parts and finished goods are in demand to replace older Castings which may have perished or reach the end of their life cycle. Due to its ability to produce complex shapes, it is also used for artistic work such as sculptures. The applications of ductile iron can be divided into four fields:

3.1 Pressure Pipes and Fittings

Much of the annual production of ductile iron is in the form of ductile iron pipe, used for water and sewer lines. It competes with polymeric materials such as PVC, HDPE, LDPE and polypropylene, which are all much lighter than steel or ductile iron; being more flexible, these require protection from physical damage. The excellent strength and toughness of ductile iron makes its pipeline to withstand the high operating pressure, municipal construction and transportation requirements.

3.2 Automobile Industry

The automotive industry is the second largest ductile iron casting application fields. Ductile iron has been used in cars in the three main areas: first, the car engine parts, second, gears and bushings, third, suspension, brakes and steering. Almost all crankshafts of the Ford Motor Company have been manufactured by ductile iron. Most of the worldwide cars are fitted with ductile iron crankshaft, instead of forged steel crankshaft. Automotive gears, for example, are being converted to ductile iron for its damping capacity and cost reductions. Ductile iron bar stock conversions are also prevalent in many fluid power applications, including glands and rod guides, cylinders, hydrostatic transmission barrels, and in high-pressure manifolds [53].

The original design of the 1000 H.P. pump frame was a steel fabrication. Converting to ductile iron achieved more uniform stress distribution, lower production cost and improved strength-to-weight ratio. The weight was reduced by 46%, which is particularly important for installations where the parts must be airlifted [54]. In design of bearing housings, compressive strength is an important factor. In this application ductile iron compares favorably with steel. Additional advantages are better machinability and vibration damping. Pistons for low speed, high pressure compressors were originally one-piece gray iron castings with 19 mm walls. As speeds increased, the need for a higher strength, lighter weight piston was achieved by casting the pistons in ductile iron and reduc-

ing wall thicknesses to 5 – 6 mm [55]. Also, a design change to a two-piece welded assembly simplified casting procedures and permitted further weight reduction. This saving in weight reduced inertia of the piston.

3.3 Agriculture, Road and Construction Applications

Modern agriculture requires a reliable and long service life of agricultural machinery. The entire agricultural industries are widely using ductile iron castings including tractor parts, plows, brackets, clamps and pulleys. For other types of agricultural machinery including bulldozers, moved into machines, cranes and compressors, ductile iron castings in these areas have a very wide range of applications.

3.4 General Engineering Applications

The machine tool industry is using the excellent engineering performance of the ductile iron to design complex machine parts. Ductile iron has high tensile strength and yield strength, and good mechanical processing properties, thus allowing production of lighter castings to keep a good rigidity. Similarly, the strength and toughness of ductile iron has made it to be widely used in all kinds of hand tools such as wrenches, clamps and gauges etc. Paper manufacturing industry is using the high strength and high elastic modulus of ductile iron. These properties can reduce the weight of the pressure drum and drying drum. Therefore, ductile iron castings have been widely used in many industrial areas worldwide. With the continuous development of metal founding, the application of ductile iron must be wider in the future.

4 CONCLUSION

The understanding of processing techniques of ductile irons is a requisite requirement to successfully convert gray cast iron to ductile iron. While the metallurgical concepts of ductile iron is the key to understanding its potential use as an engineered metal and allows the design engineer to determine its suitability in specific applications and to intelligently select the best grade.

The mechanical properties of castings made with spheroidal rather than flake graphite had high strength and ductility, good fatigue life, and impact properties. The mechanical properties of ductile irons are similar to that of steels and can often be used as a cheaper alternative, whilst still offering acceptable service performance. Ductile iron is also available in continuously cast bar stock and can be a direct replacement for carbon steel bars in a number of gears in the automotive, hydraulic, machine tool, and other industries.

REFERENCES

- [1] A. De Santis, O. Di Bartolomeo, D. Iacoviello and F. Iacoviello, "Optimal Binarization of Images by Neural Networks for Morphological Analysis of Ductile Cast Iron," *Pattern Anal Applic.*, vol. 10, pp. 125-

- 133, 2007, doi 10.1007/s10044-006-0052-8.
- [2] R. Konečná and P. Skocovský, "Relationship between Microstructure and Impact Toughness of Cast Irons with Transient forms of Graphite," *Kovové materiály, SAV*, Bratislava, 3-S, pp. 43 – 48, 1998.
- [3] N. Fatahalla, S. Bahi and O. Hussein, "Metallurgical Parameters, Mechanical Properties and Machinability of Ductile Cast," *Journal of Materials Science*, vol. 31, no. 21, pp. 5765 – 5772, 1996.
- [4] C.F. Yeung, H. Zhao and W.B. Lee, "The Morphology of Solidification of Thin-Section Ductile Iron Castings," *Materials Characterization*, vol. 40, no. 4-5, pp. 201-208, 1998.
- [5] B.I. Imasogie, A.A. Afonja and J.A. Ali, "Properties of As-Cast and Heat-Treated Nodular Graphite Cast Irons, Melts Treated With CaSi-CaF₂ Alloy," *Scandinavian Journal of Metallurgy*, vol. 30, no. 2, pp. 91-102, 2001.
- [6] J.H. Liu, X.Y. Hoo, G.L. Li and G.S. Liu, "Microvoid Evaluation of Ferrite Ductile Iron under Strain," *Materials Letter*, vol. 56, no. 5, pp. 748-755, 2002.
- [7] L.P. Dix, R. Ruxanda, J. Torrance, M. Fukumoto and D.M. Stefanescu, "Static Mechanical Properties of Ferritic and Pearlitic Lightweight Ductile Iron Castings," *AFS Transactions*, vol. 111, pp. 1149-1164, 2003.
- [8] D.M. Stefanescu, R. Ruxanda and L.P. Dix, "The Metallurgy and Tensile Mechanical Properties of Thin Wall Spheroidal Graphite Irons," *International Journal of Cast Metals Research*, vol. 16, no. 1-3, pp. 319-324, 2003.
- [9] K.L. Hayrynen, "The Production of Austempered Ductile Iron (ADI)," *World Conference on ADI*, Louisville, Kentucky USA, pp. 1-6, September 26 – 27, 2002.
- [10] M. Hafiz, "Mechanical Properties of SG-iron with Different Matrix Structure," *Journal of Materials Science*, vol. 36, pp. 1293-1300, 2001.
- [11] D.M. James, "A Design Engineer's Digest of Ductile Iron" 8th Edition," *Sorelmetal Technical Services Rio Tinto Iron & Titanium, Inc.*, USA, pp. 9-12, 2005.
- [12] V.A. Chaykin and V.V. Ishutin, "Raising of Mechanical Properties of Ductile Iron," *Casting and Metallurgy*, vol. 4, pp. 71-75, 2002.
- [13] S.J. Karsay, "Ductile Iron Production Practices," *American Foundrymen's Society Inc.*, Des Plaines, Ill, 1994.
- [14] V.I. Litovka, A.A. Sheyko and B.G. Zeliony, "Technology for Ductile Iron Production," *Foundry (Liteynoje Proizvodstvo)*, vol. 4, pp. 13-14, 1983.
- [15] S. Bočkus and A. Dobrovolskis, "Peculiarity of Producing Ferritic Ductile Iron Castings," *Materials Science (Medžiagotyra)*, vol. 10, no. 1, pp. 3-6, 2004.
- [16] V.J. Krestyanov, "Some Conditions for Producing Nodular Iron with a High Complex of As-Cast Mechanical Properties," *Foundry (Liteynoje Proizvodstvo)*, vol. 7, pp. 2-5, 1991.
- [17] L.A. Solntsev, "Influence of C/Si Ratio on Kinetics of Austenite Transformation and Structure of High-Duty Iron," *Foundry (Liteynoje Proizvodstvo)*, vol. 6, pp. 3-45, 1976.
- [18] I.A. Shaprikov "Effect of Carbon Content On The Ductile Iron Quality," *Foundry (Liteynoje Proizvodstvo)*, vol. 11, pp. 6-75, 1992.
- [19] M.P. Shebatinov, Y.Y. Abromenko and N.I. Bech, "Ductile Iron in the Production of Motor Car," Mashinostroyeniye Publishers, Moscow, 1988.
- [20] B. Ebert and A.G. SKW-Trostenberg "Developer, Producer and Supplier of Inoculants and Materials for the Foundry Industry," *Foundry (Liteynoje Proizvodstvo)*, vol. 11, 45-47, 1988.
- [21] S.E. Franklin and R.A. Stark "Application of Secondary Mass Spectroscopy Study of Graphite Morphology in Cast Iron," *Metal Science*, vol. 18, pp. 187-200, 1984.
- [22] J.P. Sadocha and J.F. Gruzleski, Proceeding of 2nd International Symposium on the Metallurgy of Cast Iron, St. Saphorin, Switzerland, Georgi, pp. 439-443, 1974.
- [23] W.C. Johnson and H.B. Smartt, "The Role of Interphase Boundary Adsorption in the Formation of Spheroidal Graphite in Cast Iron," *Metallurgical Transactions*, vol. 8A, pp. 553-565, 1977.
- [24] B. Francis, "Heterogeneous Nuclei and Graphite Chemistry in Flake and Nodular Cast Irons," *Metallurgical Transactions*, vol. 10A, pp. 21-31, 1979.
- [25] S.V. Subramanian and D. Kay, "Compacted Graphite Morphology Control," *Transactions of the American Foundrymen's Society*, vol. 90, pp.589-603, 1982.
- [26] T. Skaland, "Ductile Iron Production – A Comparison of Alternative Treatment Methods," *Proceedings of 4th Asian Foundry Congress*, 32nd Annual Convention of Australian Foundry Institute, pp. 579-597, October 1996.
- [27] T. Skaland, O. Grong and T. Grong, "A Model for the Graphite Formation in Ductile Iron Inoculation Mechanism," *Metallurgical and Materials Transactions A*, vol. 24A, pp. 2321-2345, 2003.
- [28] T. Skaland, I. Riposan, M. Chisamera and S. Stan, "New Approach to Graphite Nucleation Mechanism in Gray Irons," *Proceedings of the AFS Cast Iron Inoculation Conference*, Schaumburg, Illinois, pp. 31-41, 2005.
- [29] J.R. Keough "Austempered Ductile Iron," Ductile Iron Society, Available from: <http://www.ductile.org/didata/section4/4intro.htm>. 1998. [URL link: 14 October, 2012].
- [30] R. Elliott, *Cast Iron Technology*. Butterworths and Company Limited, London, pp. 79-85, 1988.
- [31] V.H. Patterson and M.J. Lalich, "Fifty Years of Progress in Cast Iron Inoculation," *Transactions of the American Foundrymen's Society*, vol. 70, 33-42, 1978.
- [32] K.B. Rundman, "Cooperating with Mother Nature – A Story of Physical Metallurgy of Ductile Iron – Part I," *The 35th Australian Foundry Institute National Conference*, Adelaide Australia, 31st October – 3rd November, 2004.
- [33] L.E. Umoru, J.A. Ali and A.A. Afonja, "Evaluation of the Influence of Bainitic Transformation on Some Mechanical Properties of Calcium Treated Cast Iron," *Journal of Minerals & Materials Characterization & Engineering*, vol. 6, no. 2, pp. 109-120, 2007.
- [34] B.I. Imasogie, A.A. Afonja and J.A. Ali, "Properties of Ductile Cast Iron Nodularised with Multiple Calcium-Magnesium Based Master Alloy," *Materials Science and Technology*, U.K., vol. 16, pp. 194-201, 2000.
- [35] Y.S. Lerner and G.V. Pantelev 'Magnesium Treatments in Ductile Iron Production – Part 1,' *Foundry Management and Technology*, vol. 130, no. 8, pp. 25-31, 2002.
- [36] Lerner Y.S. and Pantelev G.V. "Magnesium Treatments in Ductile Iron Production – Part 2," *Foundry Management and Technology*, vol. 131, no. 2, pp. 24-29, 2003.
- [37] P.P. Mohla, "Comparison of Latest Ductile Iron Treatment and Inoculation Techniques," *Proceedings of 4th Asian Foundry Congress*, 32nd Annual Convection of Australian Foundry Institute, pp. 557-568, 1996.
- [38] M. Atsushi "Inoculating Method In In-Mould By Melt-Sprayed of Fe-Si," Patent JP57160566A2, 1982.
- [39] K. Tsutomu, K. Koji, Y. Masaru and M. Katsuichi, "Method for Inoculation In-Mould by Electromagnetic," Patent JP57025249A2, 1982.
- [40] T. Masaharu, K. Kazuhiro and T. Hirobumi, "In-Mould Inoculants," Patent JP59137155A2, 1984.

- [41] F. Shigezo and A. Toshia "Reaction Vessel for In-Mould Inoculation, Patent JP62185859A2, 1987.
- [42] M. Fujiwara, "Secondary Inoculation Method to Inside of Casting Mould for Cast Iron Casting," Patent JP4009265A2, 1992.
- [43] E.R. Nagel and T.J. Gray "Treatment of Cast Metal in Cope Mould Pouring Basin," Patent US4779668, 1988.
- [44] P.P. Mohla and E. David "Methods of Treating Casting Metals," Patent US5390723, 1995.
- [45] Lerner Y.S. and Tukhin I.E. "Ductile Iron Treatment Using Pure Mg in the Modified Pressure Vessel And Sandwich Methods," *World Symposium on Ductile Iron*, South Carolina, October 19 – 22, 1993.
- [46] Y.S. Lerner, L.S. Aubrey and D. Craig, "In Mould Treatment Processes in Iron Foundry Practice," *Foundry Trade Journal*, vol. 9, pp. 24-31, 2001.
- [47] M. Jonuleit and B. Ebert, "Ductile Iron Production with Cored Wire," *Foundry Trade Journal*, vol. 9, pp. 19-25, 2001.
- [48] H. Trager, K.H. Kleemann, K.J. Relfferscheid and D.H. Gumbinger, "Process and Apparatus for Inoculating Cast Iron," Patent US4867227, 1988.
- [49] R. Sillén "The PQ-CGI In-Mold Process," Available from: <http://www.ialonso.com/software/pqcgi.hmt>. 2006. [URL link: 14 October, 2012].
- [50] Q. Cai and B. Wei "Recent Development of Ductile Cast Iron Production Technology in China," *China Foundry*, vol. 5, no. 2, pp. 82-91, 2008.
- [51] N. Fatahalla, S. Bahi and O. Hussein, "Metallurgical Parameters, Mechanical Properties and Machinability," *Journal of Materials Science*, vol. 31, no. 21, pp. 5765-5772, 1996.
- [52] J.R. Keough, "Ductile Iron Data for Design Engineers," John Wiley and Son Inc., 1998.
- [53] J.R. Keough and K.L. Hayrynen, "Automotive Applications of Austempered Ductile Iron (ADI): A Critical Review," *Society of Automotive Engineers*, Michigan, USA, 2000, 2000-01-0764.
- [54] K.R. Brandenberg, J. Ravenscroft, A. Rimmer and K.L. Hayrynen, "An ADI Crankshaft Designed for High Performance in TVR's Tuscan Speed Six Sports Car," *Society of Automotive Engineers International*, 2001-01-0408, 2001.
- [55] S. Bočkus, A. Venckūnas and G. Žaldarys, "Relation between Section Thickness, Microstructure and Mechanical Properties of Ductile Iron Castings," *Materials Science (Medžiagotyra)*, vol. 14, no. 2, pp. 115-118, 2008.

IJSER